

# STANLEY



 **ilumitec**<sup>®</sup>  
INTERNATIONAL

## LIGHTING CATALOGUE

- LED PANELS
- COMMERCIAL LIGHTING
- EXHAUST FANS
- POWER STRIPS
- EXTENSION CORDS
- SURGE & VOLTAGE PROTECTORS
- SOLAR LIGHTING

# STANLEY



## EXHAUST FANS

## EXHAUST FAN

### SXIM-XF-01



Built for efficient and continuous ventilation, this exhaust fan is equipped with a DC motor and double ball bearing system that ensures smoother rotation, lower noise, and extended lifespan. The 100% copper wire motor improves electrical conductivity and performance stability, delivering reliable airflow for residential and commercial environments.

#### FEATURES

- High-efficiency DC motor
- Double ball bearing system for longer durability
- 100% copper wire coil for better conductivity
- Low noise operation
- Energy saving performance
- Stable and continuous airflow
- Easy installation and maintenance

#### APPLICATION

- Bathrooms
- Kitchens
- Warehouses
- Commercial spaces

**CE IP20**

#### PHYSICAL DATA

Finish	White
Protection Level - IP	IP 20
Installation Size	200 X 200 mm
Type of Installation	Wall / Ceiling Mounted
Body Material	PP
Coil Material	100% Copper
Motor Type	DC Motor
Bearing Type	Double Ball Bearing

#### ELECTRICAL DATA

Input Power	12W
Energy Saving	YES
Operating Voltage	80-245V~
Frequency	50-60 Hz
Air Flow	220 CFM

#### DIMENSIONS

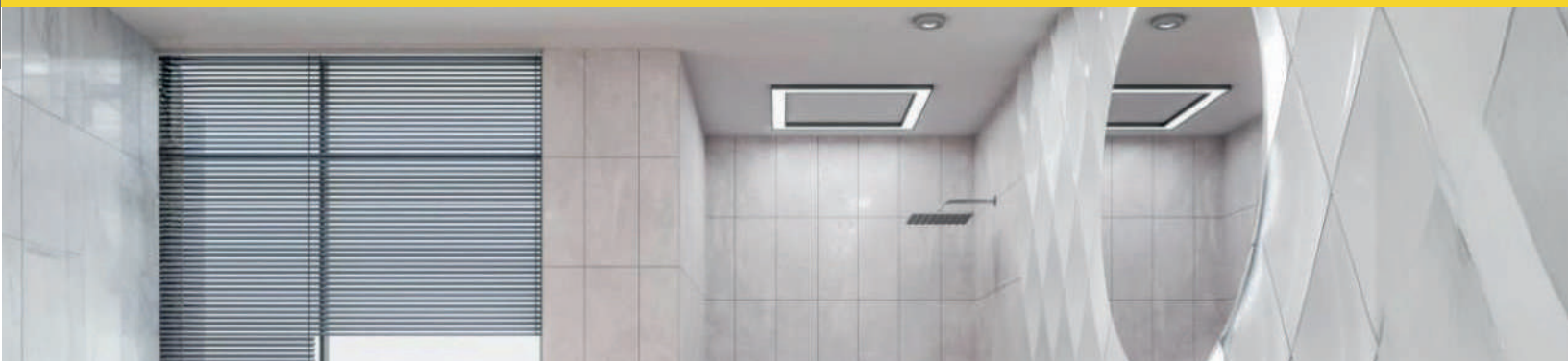
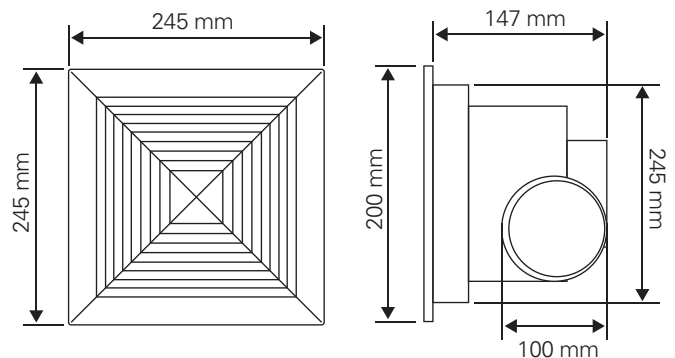

**THE MEASURE OF A PRO™**

## EXHAUST FAN WITH LED CCT LAMP

### SXIM-XF-02



Designed for efficient ventilation, this exhaust fan features a compact structure built with durable ABS panel and PP body. Its energy-saving 12W motor delivers stable high-speed performance at 1200 r/min, ensuring effective air circulation with an airflow capacity of 120 m³/h. Ideal for maintaining fresh and clean environments in residential and commercial spaces.

#### FEATURES

- Energy-saving 12W motor
- High airflow performance
- Durable ABS front panel
- Resistant PP body structure
- Low noise operation
- Stable high-speed rotation
- Easy installation
- Modern compact design

#### APPLICATION

- Bathrooms
- Kitchens
- Laundry areas
- Offices
- Storage rooms
- Commercial spaces
- Small warehouses

**CE IP20**

#### PHYSICAL DATA

Finish	White
Protection Level - IP	IP 20
Installation Size	200mm x 200mm
Type of Installation	Ceiling Mounted
Panel Material	ABS
Body Material	PP
Motor Type	DC

#### ELECTRICAL DATA

Input Power	23W
Energy Saving	YES
Operating Voltage	80-245V~
Frequency	50-60 Hz
Air Flow	120 m³/h
Fan Speed	1300 r/min

#### DIMENSIONS

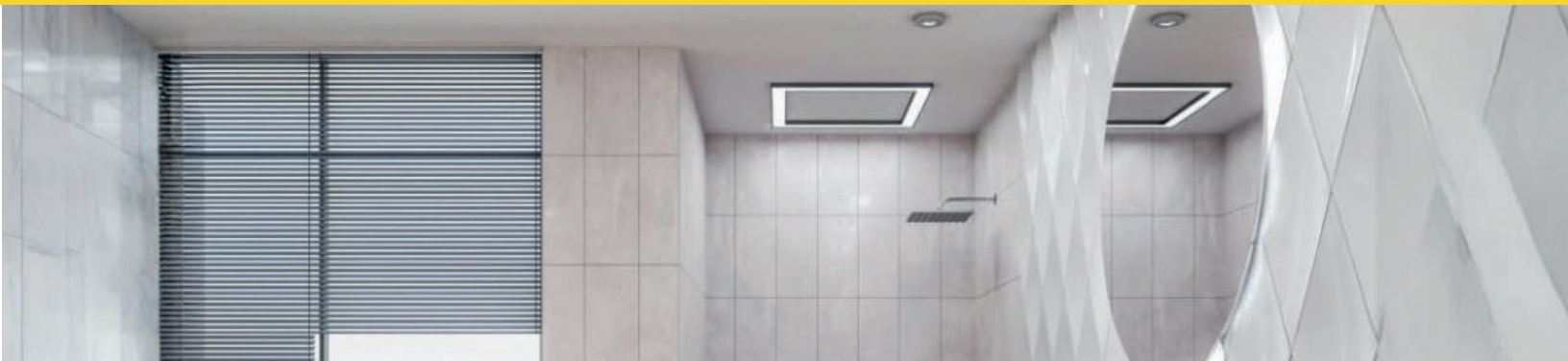
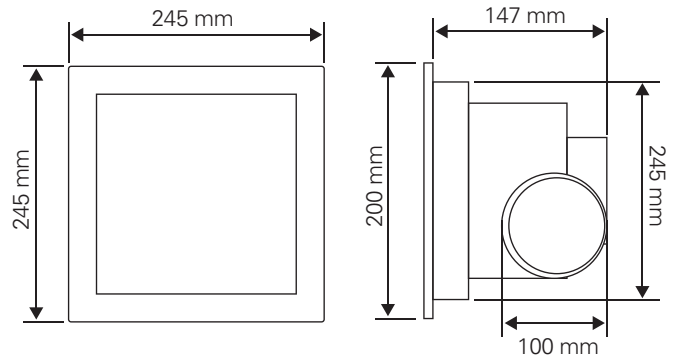

**THE MEASURE OF A PRO™**

## EXHAUST FAN

### SXIM-XF-03



Engineered for high-efficiency ventilation, this exhaust fan is equipped with a DC double ball bearing motor that ensures stable rotation, enhanced durability, and long operational life. Its reinforced structure combines an ABS front panel with an iron motor body, providing strength and resistance for continuous use. With a powerful airflow capacity of 190 m<sup>3</sup>/h, it is ideal for medium to large enclosed areas.

#### FEATURES

- High-performance 12W motor
- AC double ball bearing system for longer lifespan
- Aluminium wire motor coil
- Strong iron motor housing
- Durable ABS decorative front panel
- High airflow efficiency (190 m<sup>3</sup>/h)
- Stable 1250 r/min rotation
- Easy ceiling installation
- Modern square grille design

#### APPLICATION

- Bathrooms
- Commercial restrooms
- Kitchens
- Offices
- Small warehouses
- Storage rooms
- Utility rooms

**CE** **IP20**

#### PHYSICAL DATA

Finish	White
Protection Level - IP	IP 20
Installation Size	200x200mm
Type of Installation	Ceiling Mounted
Panel Material	ABS
Body Material	Iron Motor Housing
Motor Type	AC Double Ball Bearing Motor

#### ELECTRICAL DATA

Input Power	12W
Energy Saving	YES
Operating Voltage	85-245V~
Frequency	50-60 Hz
Air Flow	200 CFM
Fan Speed	1200 r/min

#### DIMENSIONS

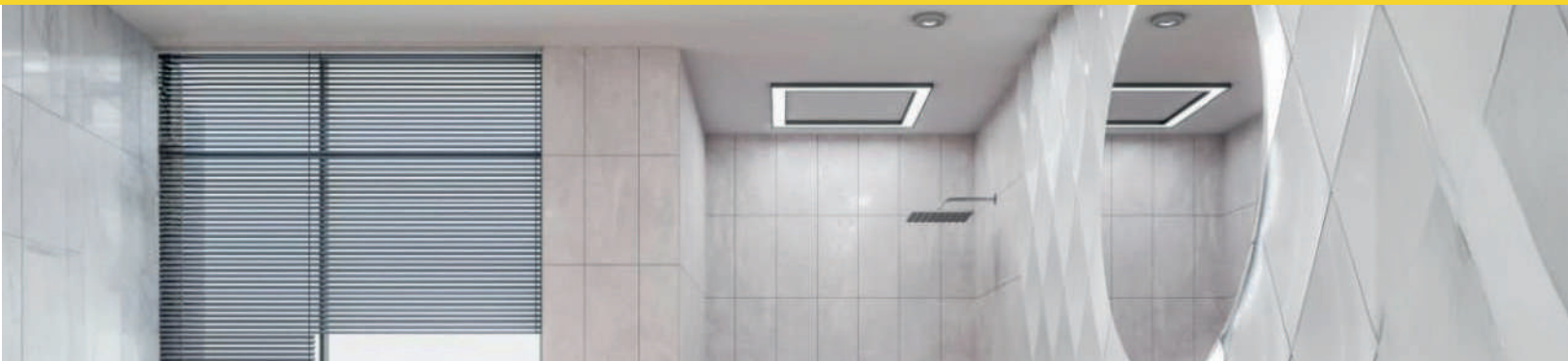
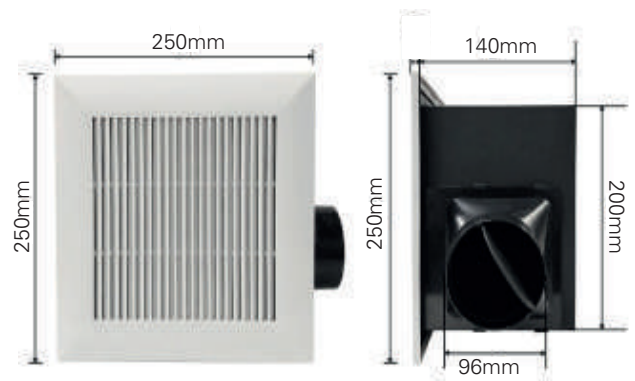

**THE MEASURE OF A PRO™**

## EXHAUST FAN WITH LED LAMP

### SXIM-XF-04



This 8-inch exhaust fan combines high-efficiency ventilation with integrated lighting functionality. Equipped with a DC double ball bearing motor and 100% copper wire coil, it ensures smooth operation, low noise, and extended service life. The built-in 3CCT selectable lighting system allows users to adjust color temperature according to their environment needs, making it ideal for modern residential and commercial applications.

#### FEATURES

- High-efficiency DC motor
- Double ball bearing system for extended durability
- 100% copper wire coil for superior conductivity
- Wide voltage compatibility (85–245V)
- Integrated 3 CCT lighting selection
- Stable, low-noise performance
- Modern square design

#### APPLICATION

- Bathrooms
- Kitchens
- Laundry rooms
- Offices
- Commercial spaces

**CE** **IP20**

#### PHYSICAL DATA

Finish	White
Protection Level - IP	IP 20
Dimensions	8" (200mm)
Type of Installation	Ceiling Mounted
Panel Material	ABS
Coil Material	Double Ball Bearing Copper
Motor Type	DC

#### ELECTRICAL DATA

Input Power	23W
Energy Saving	YES
Operating Voltage	85-245V~
Frequency	50-60 Hz
CCT	3000K, 4000K, 6500K

#### DIMENSIONS

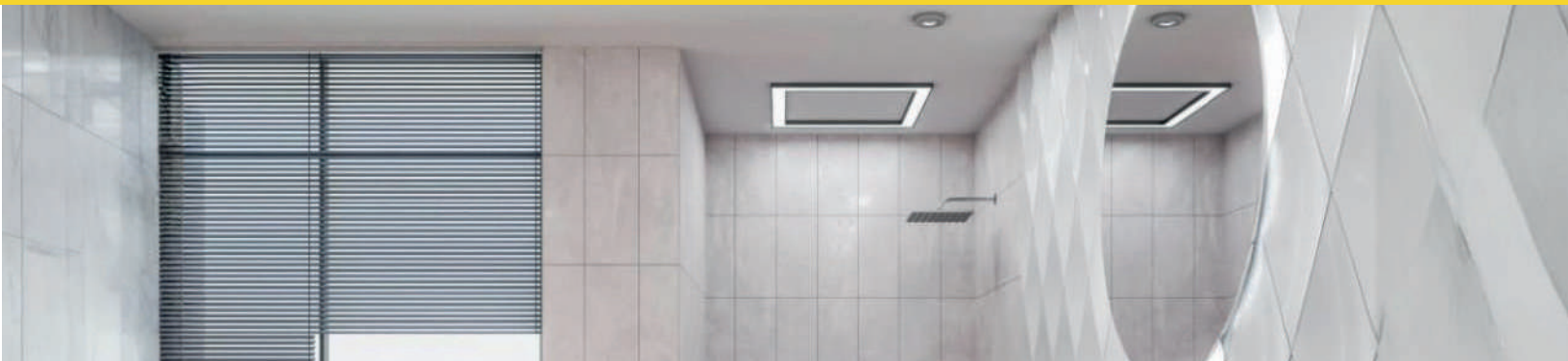
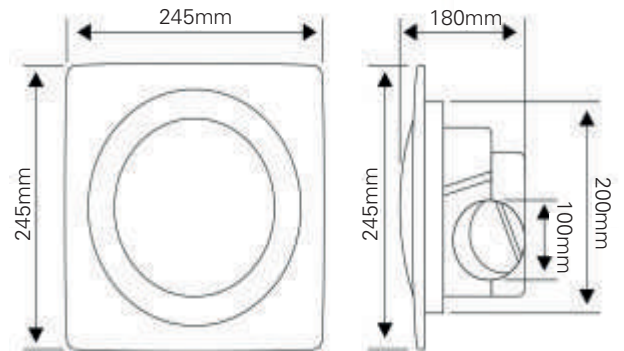

**THE MEASURE OF A PRO™**

## EXHAUST FAN

### SXIM-XF-05



Designed for efficient ventilation in compact spaces, this 6-inch exhaust fan is powered by a high-efficiency DC motor with double ball bearing system for smoother rotation and extended lifespan. The 100% copper wire coil ensures superior electrical conductivity, energy efficiency, and stable performance for continuous air extraction.

#### FEATURES

- High-efficiency DC motor
- Double ball bearing system for durability
- 100% copper wire motor coil
- Energy-saving performance
- Stable and low-noise operation
- Compact square design
- Easy wall or ceiling installation

#### APPLICATION

- Bathrooms
- Small kitchens
- Laundry areas
- Offices
- Utility rooms
- Storage spaces

**CE** **IP20**

#### PHYSICAL DATA

Finish	White
Protection Level - IP	IP 20
Installation Size	150x150mm
Type of Installation	Ceiling Mounted
Panel Material	ABS
Coil Material	Double Ball Bearing Copper
Motor Type	DC

#### ELECTRICAL DATA

Input Power	8W
Energy Saving	YES
Operating Voltage	80-245V~
Frequency	50-60 Hz

#### DIMENSIONS

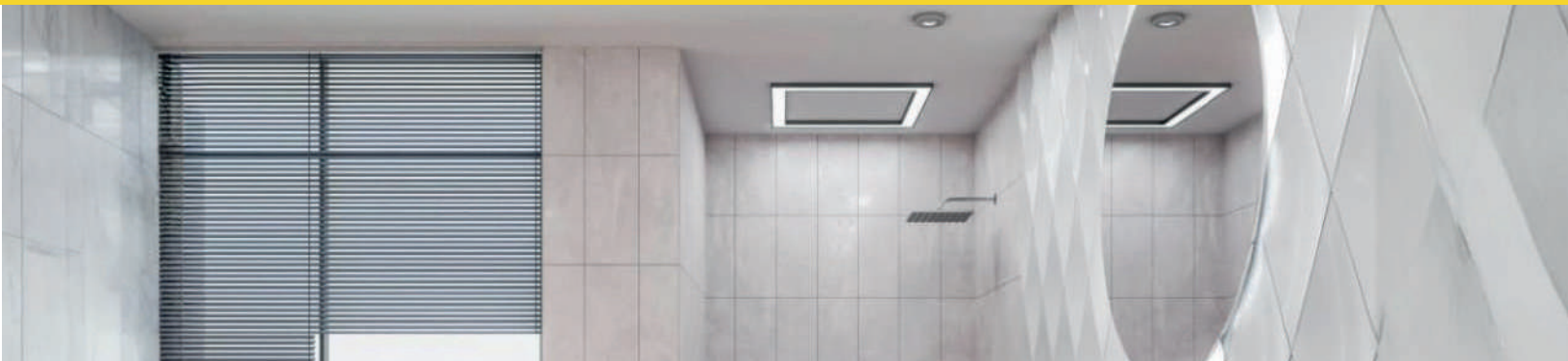
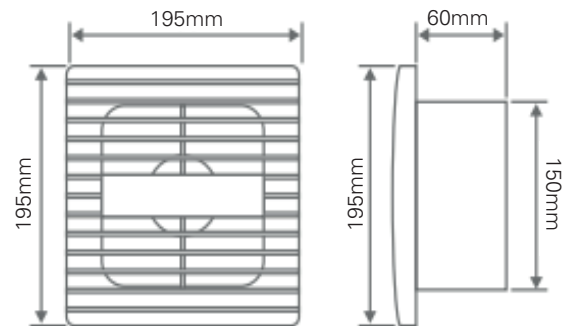

**THE MEASURE OF A PRO™**

# STANLEY



## LED PANELS

# STANLEY®

## RECESSED LED PANEL LIGHT

### SXIM-P01 & P05

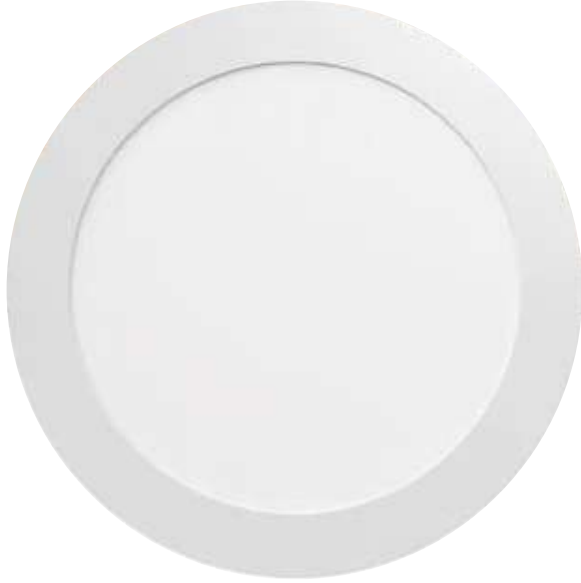

#### AVAILABLE WATTAGE OPTIONS:

- 12W
- 18W
- 24W

#### BENEFITS:

- Energy efficiency.
- Improved environmental performance.
- Ability to operate in cold conditions.
- No heat or UV emissions.
- Design flexibility.
- Instant lighting and the ability to withstand frequent switching.
- Long lifespan.
- General lighting for limited build-in height.

(CCT) Color Temperature Switch



## IP20

#### SPECIFICATIONS

Shape:	Round LED Lamp
Fitting:	Recessed Ceiling
Finish:	White

#### ADDITIONAL INFORMATION

Volt:	100-277V 50-60Hz
Beam Angle:	110°
Certification:	CE

#### AVAILABLE WATTAGE OPTIONS

Power	Tone	Brightness	Size	Dimmable / Non Dimmable	Model
12W	6000K	130Lm	170mm x 17mm	Non Dimmable	SXIM-P01-12W6K
18W	6000K	130Lm	220mm x 17mm	Non Dimmable	SXIM-P01-18W6K
12W	3000K, 4000K, 6500K	1000Lm	170mm x 17mm	Non Dimmable	SXIM-P05-R12WCCT
18W	3000K, 4000K, 6500K	1100Lm, 1200Lm, 1100Lm	220mm x 17mm	Non Dimmable	SXIM-P05-R18W-CCT
24W	3000K, 4000K, 6500K	1610Lm	280mm x 17mm	Non Dimmable	SXIM-P05-R24WCCT



## THE MEASURE OF A PRO™

# STANLEY®

## RECESSED LED PANEL LIGHT

### SXIM-P02 & P06



#### AVAILABLE WATTAGE OPTIONS:

- 12W
- 18W

#### BENEFITS:

- Energy efficiency.
- Improved environmental performance.
- Ability to operate in cold conditions.
- No heat or UV emissions.
- Design flexibility.
- Instant lighting and the ability to withstand frequent switching.
- Long lifespan.
- General lighting for limited build-in height.

(CCT) Color Temperature Switch

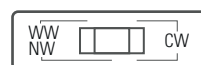

# IP20

#### SPECIFICATIONS

Shape:	Square LED Lamp
Fitting:	Recessed Ceiling
Finish:	White

#### ADDITIONAL INFORMATION

Volt:	100-277V 50-60Hz
Beam Angle:	110°
Certification:	CE

#### AVAILABLE WATTAGE OPTIONS

Power	Tone	Brightness	Size	Dimmable / Non Dimmable	Model
12W	6000K	720Lm	170mm x 170mm	Non Dimmable	SXIM-P02-12W6K
18W	6000K	1440Lm	220mm x 220mm	Non Dimmable	SXIM-P02-18W6K
12W	3000K,4000K,6500K	733Lm/824Lm/744Lm	170mm x 170mm	Non Dimmable	SXIM-P06-S12WCCT
18W	3000K,4000K,6500K	1430Lm/1580Lm/1430Lm	220mm x 220mm	Non Dimmable	SXIM-P06-S18WCCT



## THE MEASURE OF A PRO™

# STANLEY®

## LED SURFACE PANEL LIGHT

### SXIM-P03 & P07



#### AVAILABLE WATTAGE OPTIONS:

- 12W
- 18W
- 24W

#### BENEFITS:

- Energy efficiency.
- Improved environmental performance.
- Ability to operate in cold conditions.
- No heat or UV emissions.
- Design flexibility.
- Instant lighting and the ability to withstand frequent switching.
- Long lifespan.
- General lighting for limited build-in height.

(CCT) Color Temperature Switch



# IP20

#### SPECIFICATIONS

Shape:	Round LED Lamp
Fitting:	Surface Mounted Ceiling
Finish:	White or Black

#### ADDITIONAL INFORMATION

Volt:	100-277V 50-60Hz
Beam Angle:	110°
Certification:	CE

#### AVAILABLE WATTAGE OPTIONS

Power	Tone	Brightness	Size	Dimmable / Non Dimmable	Model
12W	6000K	750Lm	D-160mm H-28mm	Non Dimmable	SXIM-P03-12W6K
18W	6000K	1200Lm	D-210mm H-28mm	Non Dimmable	SXIM-P03-18W6KWH
18W	6000K	1200Lm	D-210mm H-28mm	Non Dimmable	SXIM-P03-18W6KBK
18W	3000K, 4000K, 6500K	1248Lm	D-210mm H-28mm	Non Dimmable	SXIM-P07-18WCTWH
18W	3000K, 4000K, 6500K	1248Lm	D-210mm H-28mm	Non Dimmable	SXIM-P07-18WCTBK
24W	3000K, 4000K, 6500K	1570Lm	D-280mm H-35mm	Non Dimmable	SXIM-P07-R24WCCT



## THE MEASURE OF A PRO™

# STANLEY®

## LED SURFACE MOUNTED PANEL LIGHT

### SXIM-P04 & P08



#### AVAILABLE WATTAGE OPTIONS:

- 12W
- 18W
- 24W

#### BENEFITS:

- Energy efficiency.
- Improved environmental performance.
- Ability to operate in cold conditions.
- No heat or UV emissions.
- Design flexibility.
- Instant lighting and the ability to withstand frequent switching.
- Long lifespan.
- General lighting for limited build-in height.

#### (CCT) Color Temperature Switch



# IP20

#### SPECIFICATIONS

Shape:	Square LED Lamp
Fitting:	Surface Mounted Ceiling
Finish:	White or Black

#### ADDITIONAL INFORMATION

Volt:	100-277V 50-60Hz
Beam Angle:	110°
Certification:	CE

#### AVAILABLE WATTAGE OPTIONS

Power	Tone	Brightness	Size	Dimmable / Non Dimmable	Model
12W	6000K	720Lm	170mm x 170mm x 28mm	Non Dimmable	SXIM-P04-12W6K
18W	6000K	1440Lm	220mm x 220mm x 28mm	Non Dimmable	SXIM-P04-18W6KWH
18W	6000K	1440Lm	220mm x 220mm x 28mm	Non Dimmable	SXIM-P04-18W6KKBK
12W	3000K, 4000K, 6500K	815Lm	160mm x 170mm x 28mm	Non Dimmable	SXIM-P08-S12WCCT
18W	3000K, 4000K, 6500K	1248Lm	220mm x 220mm x 28mm	Non Dimmable	SXIM-P08-18WCTBK
18W	3000K, 4000K, 6500K	1080Lm, 1200Lm, 1080Lm	220mm x 220mm x 28mm	Non Dimmable	SXIM-P08-18WCTWH
24W	3000K, 4000K, 6500K	1080Lm, 1200Lm, 1080Lm	282mm x 282mm x 28mm	Non Dimmable	SXIM-P08-S24WCCT



**THE MEASURE OF A PRO™**

# STANLEY®

## LED SURFACE PANEL LIGHT WITH MOTION SENSOR

**SXIM-P09-18WCCT**



### AVAILABLE WATTAGE OPTIONS:

- 18W CCT

### BENEFITS:

- Energy efficiency.
- Improved environmental performance.
- Ability to operate in cold conditions.
- No heat or UV emissions.
- Design flexibility.
- Instant lighting and the ability to withstand frequent switching.
- Long lifespan.
- General lighting for limited build-in height.

(CCT) Color Temperature Switch



# IP20

### SPECIFICATIONS

Shape:	Round LED Lamp With Motion Sensor
Fitting:	Surface Mounted Ceiling
Finish:	White

### ADDITIONAL INFORMATION

Volt:	100-277V 50-60Hz
Beam Angle:	110°
Certification:	CE

### AVAILABLE WATTAGE OPTIONS

Power	Tone	Brightness	Size	Dimmable / Non Dimmable	Model
18W	3000K/4000K/6500K	1440Lm/1440Lm/1415Lm	D-210mm H-37mm	Non Dimmable	SXIM-P09-18WCCT



**THE MEASURE OF A PRO™**

# STANLEY®

## DIMMABLE LED PANEL

### SXIM-P10-R6-5CCT/R12W-5CCT



#### AVAILABLE WATTAGE OPTIONS:

- 6W CCT
- 12W CCT

#### BENEFITS:

- Energy efficiency.
- Improved environmental performance.
- Ability to operate in cold conditions.
- No heat or UV emissions.
- Design flexibility.
- Instant lighting and the ability to withstand frequent switching.
- Long lifespan.
- General lighting for limited build-in height.

(CCT) Color Temperature Switch



# IP20

#### SPECIFICATIONS

Shape:	Round LED Lamp
Fitting:	Surface Mounted Ceiling
Finish:	White

#### ADDITIONAL INFORMATION

Volt:	100-130V 50-60Hz
Beam Angle:	110°
Certification:	CE

#### AVAILABLE WATTAGE OPTIONS

Power	Tone	Brightness	Size	Dimmable / Non Dimmable	Model
6W	2700K/3000K/3500K/4000K/5000K	450 Lm	D-120mm H-20mm	Dimmable	SXIM-P10-R6W-5CCT
12W	2700K/3000K/3500K/4000K/5000K	945 Lm	D-170mm H-20mm	Dimmable	SXIM-P10-R12W-5CCT



## THE MEASURE OF A PRO™

# STANLEY



## COMMERCIAL LIGHTING

# STANLEY

## LED UFO HIGHBAY CCT & POWER SELECT

**SXIM-UFO-01-100PS-CCT**



Power Selectable: 3-IN-ONE, 60W, 80W, 100W  
 3 CCT Selectable: 4000K, 5000K, 6000K  
 3 beam angles Selectable : 60°, 90°, 105° with zoomable optic design by simple rotation, Tool free Installation and Maintenance.  
 The ripple-like lens cover diffuses the dazzling light generated by individual LEDs.

### FEATURES

- Built in high luminous efficiency LED Chip and Driver.
- Fast connection
- IP65
- Adjustable Beam Angle
- High efficacy to improve product ROI

### APPLICATION

- Factory Workshop
- Warehouse
- Parking Lot
- Conference Room
- Storage Room
- Sports Field



**CE IP65**



**Multi Beam Angle  
Switchable**



**Multi Wattage  
Switchable**



**Multi Color  
Temperature  
(CCT)**

### OPTICAL DATA

Color Temperature	4000k, 5000k, 6000k
Luminous Flux	10230, 13200, 15950 Lm
Beam Angle	60°, 90°, 105° Adjustable
Type of Distribution	Direct Symmetrical
Optical Material	Diffuser PC
Life Span	50 000 Hrs

### PHYSICAL DATA

Finish	Black
Protection Level - IP	IP65
Dimensions	225 X 142 mm
Type of Installation	Pendant, Ceiling, Wall
Body Frame	Aluminium
Operation Temperature	-30°C to +45°C

### ELECTRICAL DATA

Input Power	60W, 80W, 100W
Power Switchable	YES
Operating Voltage	100-277V
Frequency	50-60 Hz
Power Factor	>0.9
CRI	80
Dimmable	NO

### DIMENSIONS

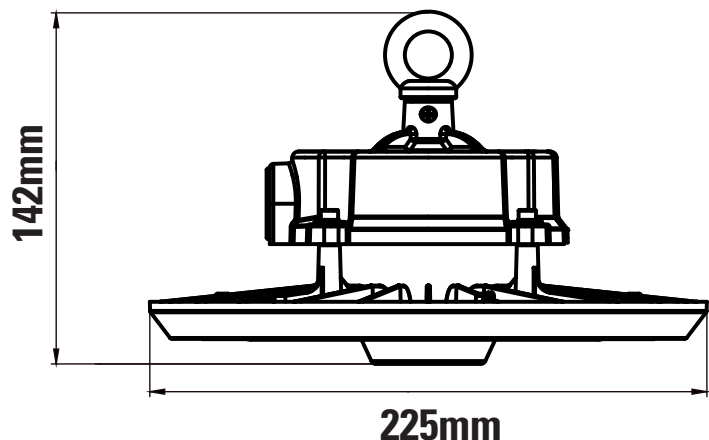

### ADDITIONAL INFORMATION

New heat dissipation system  
to ensure long lifetime



**THE MEASURE OF A PRO™**

# STANLEY®

## LED UFO HIGHBAY CCT & POWER SELECT

**SXIM-UFO-01-100PS-CCT**

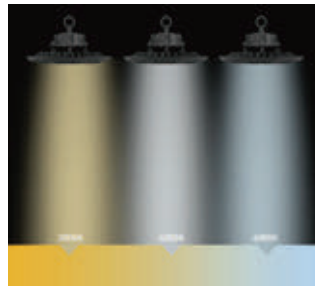

**3CCT Selectable**  
4000K, 5000K, 6000K

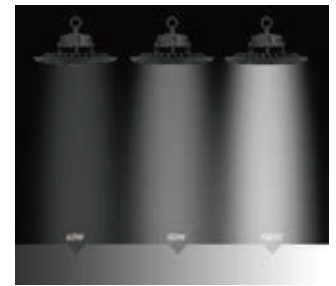

**3 Power-in-1**  
60W/80W/100W  
selectable

**Rotate the lens to change  
the beam Angle**

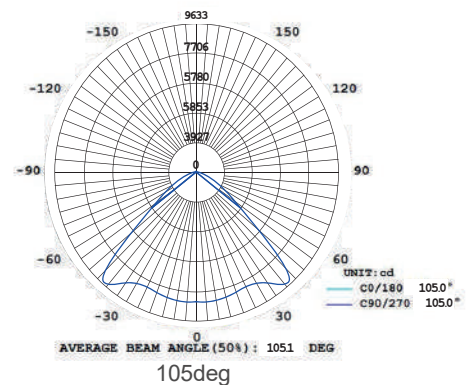
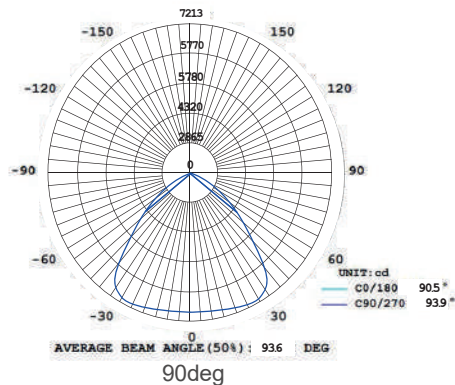
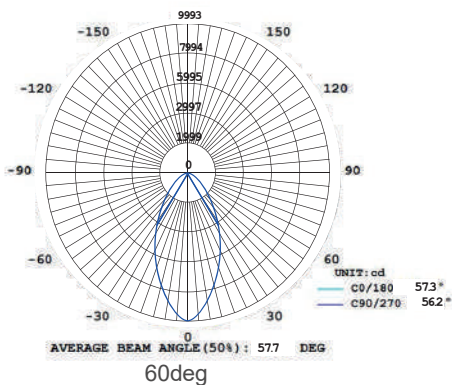

**THE MEASURE OF A PRO™**

# STANLEY

## LED UFO Highbay CCT & Power Select

### SXIM-UFO-01-200PS-CCT



Power Selectable: 3-IN-ONE, 110W, 150W, 200W

3 CCT Selectable: 4000K, 5000K, 6000K

3 beam angles Selectable : 60°, 90°, 105° with zoomable optic design by simple rotation, Tool free Installation and Maintenance

The ripple-like lens cover diffuses the dazzling light generated by individual LEDs.

#### FEATURES

- Built in high luminous efficiency LED Chip and Driver.
- Fast connection
- IP65
- Adjustable Beam Angle
- High efficacy to improve product ROI

#### APPLICATION

- Factory Workshop
- Warehouse
- Parking Lot
- Conference Room
- Storage Room
- Sports Field



CE IP65



Multi Beam Angle  
Switchable



Multi Wattage  
Switchable



Multi Color  
Temperature  
(CCT)

#### OPTICAL DATA

Color Temperature	4000K , 5000K, 6000K
Luminous Flux	18755, 24750, 31900 Lm
Beam Angle	60°, 90°, 105° Adjustable
Type of Distribution	Direct Symmetrical
Optical Material	Diffuser PC
Life Span	50 000 Hrs

#### PHYSICAL DATA

Finish	Black
Protection Level - IP	IP 65
Dimensions	250 X 162 mm
Type of Installation	Pendant , Ceiling, Wall
Body Frame	Aluminium
Operation Temperature	-30°C to +45°C

#### ELECTRICAL DATA

Input Power	110W, 150W, 200W
Power Switchable	YES
Operating Voltage	100-277V
Frequency	50-60 Hz
Power Factor	>0.9
CRI	80
Dimmable	NO

#### DIMENSIONS

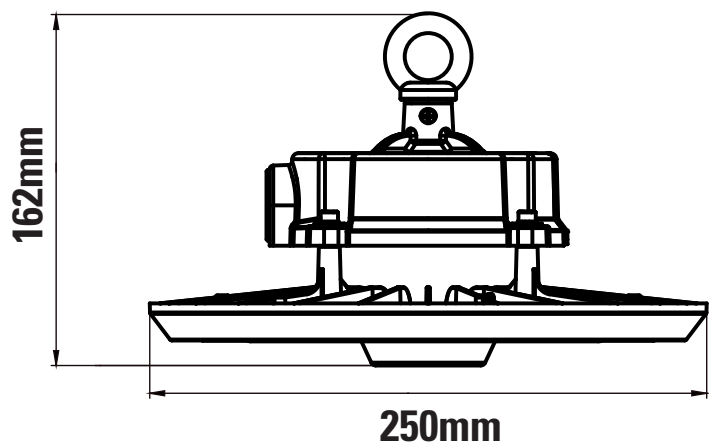

#### ADDITIONAL INFORMATION

New heat dissipation system  
to ensure long lifetime



**THE MEASURE OF A PRO™**

# STANLEY

## LED UFO HIGHBAY CCT & POWER SELECT

SXIM-UFO-01-200PS-CCT

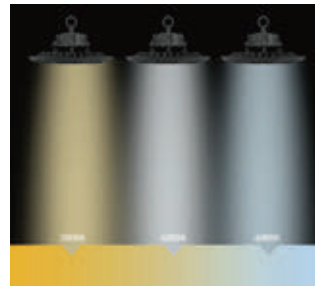

**3CCT Selectable**  
4000K, 5000K, 6000K

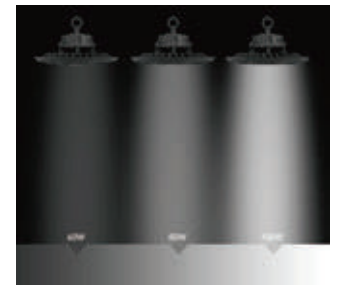

**3 Power-in-1**  
110W/150W/200W  
selectable

Rotate the lens to change  
the beam Angle

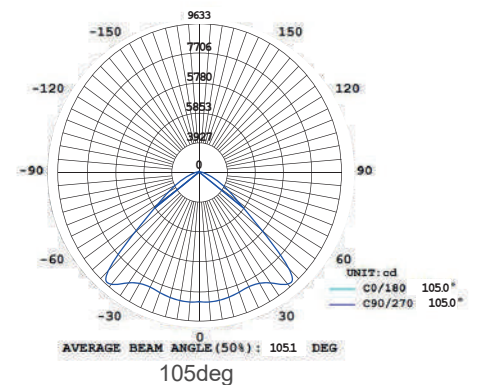
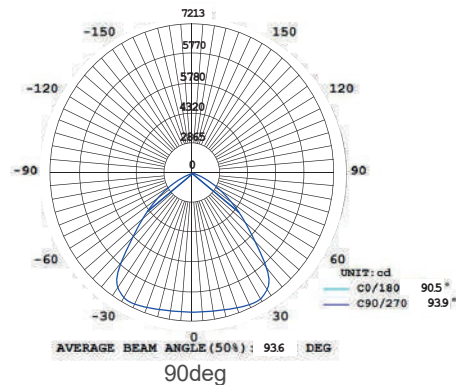
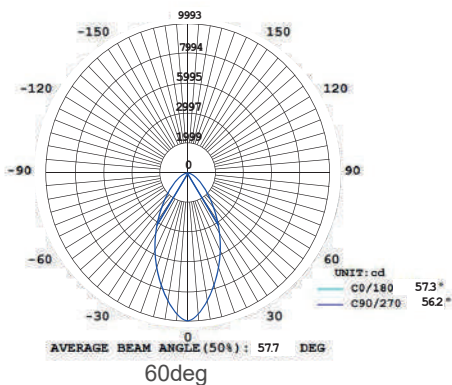

**THE MEASURE OF A PRO™**

# STANLEY

## LED CANOPY LAMP

### SXIMCAN01-PSCCT



The CAN-01 Selectable Canopy Light is a contractor experience LED canopy light – designed to save you money, save you time, and install quickly. 3 selectable lumen outputs for different ceiling heights and 3 selectable CCT color outputs. Fast installation that's prime for an easy retrofit – engineered with your experience first.

#### FEATURES

- Built in high luminous efficiency LED Chip and Driver.
- 3 Level Power Switchable
- Fast connection, IP65

#### APPLICATION

- Industrial Areas
- Sidewalks
- Commercial Areas
- Parks
- Schools
- And others.



**LED**



Indoor / Outdoor

**Multi Wattage Switchable**



**Multi Color Temperature (CCT)**



**Easy Installation**



**Water Proof**

#### OPTICAL DATA

Color Temperature (CCT)	4000K,5000K,6000K
Luminous Flux	5440Lm, 8160Lm 11560Lm, 13600Lm
Beam Angle	100°
Type of Distribution	Direct Symmetrical
Life Span	50 000 Hrs

#### PHYSICAL DATA

Finish	Black
Protection Level - IP	IP65
Dimensions	242x242x80mm
Type of Installation	Surface Mounted
Body Frame	Die-Cast Aluminium
Weight	2.2 Kg
Operation Temperature	-40°C to +50°C

#### ELECTRICAL DATA

Input Power	40W,60W,80W,100W
Power Switchable	YES
Operating Voltage	120-277V
Frequency	50-60 Hz
Power Factor	>0.95
CRI	70

#### DIMENSIONS



#### LUMINOUS INTENSITY DISTRIBUTION

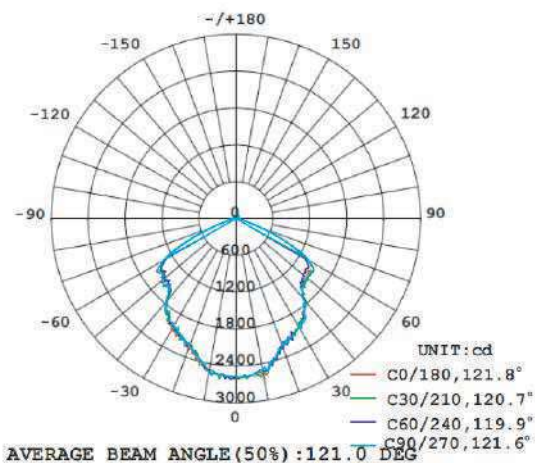

**THE MEASURE OF A PRO™**

# STANLEY

## LED WALL LAMP

### SXIMWP01-PSCCT



Rugged, die-cast housing with advanced thermal management system ensures reliability and durability. Weather-proof, gasketed driver compartment protects electronics against environmental elements.

Tunable CCT for 3000K, 4000K, 5000K, Color Temperature Options

Anti-UV Prismatic Translucent Lens Designed to Shape the Light Distribution and Uniformity.

Mounting via J-box or Surface Conduit. Casting Thermally Conducts LED Heat to Optimize Performance and Long Life.

Pre-Installed Photocell Sensor

#### FEATURES

- Built in high luminous efficiency LED Chip and Driver.
- 3 Level Power Switchable
- Fast connection
- IP65

#### APPLICATION

- Industrial Areas
- Sidewalks
- Schools
- Residential

Outdoor



**PHOTOCELL  
SENSOR**



**Multi Wattage  
Switchable**



**Multi Color  
Temperature  
(CCT)**



**Easy  
Installation**



**Water  
Proof**

#### OPTICAL DATA

Color Temperature (CCT)	4000K, 5000K, 6000K
Luminous Flux	1890Lm, 2520Lm 3150Lm, 3780Lm
Beam Angle	100°
Type of Distribution	Direct Symmetrical
Life Span	50 000 Hrs
Weight	0.52 kg

#### PHYSICAL DATA

Finish	Black
Protection Level - IP	IP65
Dimensions	144x224x85mm
Type of Installation	Surface Mounted
BodyFrame	Die-Cast Aluminium
Optical Material	Diffuser PC
Operation Temperature	-40°C to +50°C

#### ELECTRICAL DATA

Input Power	15W, 20W, 25W, 30W
Power Switchable	YES
Operating Voltage	120-277 V
Frequency	50-60 Hz
Power Factor	>0.95
CRI	70

#### DIMENSIONS



#### LUMINOUS INTENSITY DISTRIBUTION

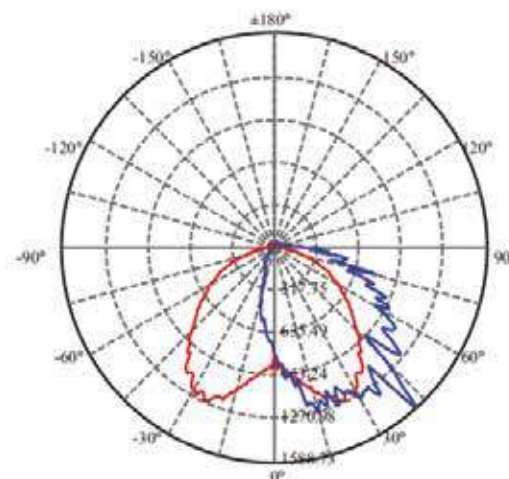

**THE MEASURE OF A PRO™**

# STANLEY

## LED WALL LAMP

### SXIMWP02-PSCCT



Two-Piece Die-Cast Aluminum Housing with Thermally Conductive LED Panel and Electrical Chamber

Tunable CCT for 4000K, 5000K, 6000K, Color Temperature Options

Anti-UV Prismatic Translucent Lens Designed to Shape the Light Distribution and Uniformity.

Mounting via J-box or Surface Conduit

#### FEATURES

- Built in high luminous efficiency LED Chip and Driver.
- 3 Level Power Switchable
- Fast connection
- IP65

#### APPLICATION

- Industrial Areas • Parks
- Sidewalks • Schools
- Squares • And others.

Indoor / Outdoor



LED



Multi Wattage Switchable



Multi Color Temperature (CCT)



Easy Installation



Water Proof

#### OPTICAL DATA

Color Temperature (CCT)	4000K, 5000K, 6000K
Luminous Flux	3750Lm, 5625Lm
	7500Lm, 10000Lm
Beam Angle	100°
Type of Distribution	Direct Symmetrical
Life Span	50 000 Hrs

#### PHYSICAL DATA

Finish	Black
Protection Level - IP	IP65
Dimensions	363x233x163mm
Type of Installation	Surface Mounted
Body Frame	Die-Cast Aluminium
Weight	2.05 Kg
Operation Temperature	-40°C to +50°C

#### ELECTRICAL DATA

Input Power	30W, 45W, 60W, 80W
Power Switchable	YES
Operating Voltage	120-277V
Frequency	50-60 Hz
Power Factor	>0.95
CRI	70

#### DIMENSIONS

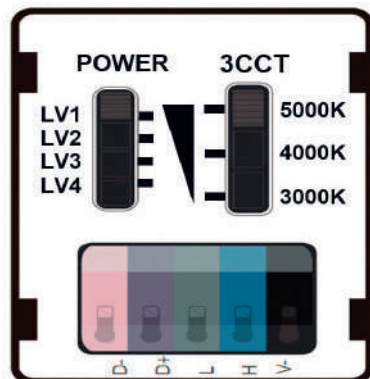

#### LUMINOUS INTENSITY DISTRIBUTION

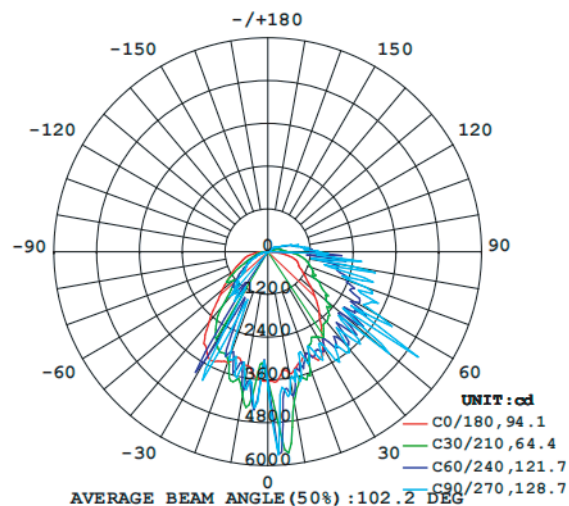

THE MEASURE OF A PRO™

## LED LINEAR LIGHT CCT

### SXIML01- CCT



LED Linear luminaire, homogeneous light distribution without shadows, for a continuous, clean and simple lighting system. Modern and compact design with LED strip and opalized diffuser.

With 3 installation methods: Pendant, surface-mounted, or recessed/Trimless

#### FEATURES

- 3 Color Switchable Selection 3000K/4000K/6500K
- 1.5 Mt Pendant Kit Adjustable
- Ability to operate in cold conditions.
- Design flexibility.
- General lighting for limited build-in height.
- Instant lighting and the ability to withstand frequent switching.
- Interconnectable

#### APPLICATION

- Offices
- Commercial Areas
- Stores
- Educational Institutions



Multi Color Temperature (CCT)



Eco Friendly



3 Type of Installation

Hanging, Surface & Recessed

#### OPTICAL DATA

Color Temperature (CCT)	3000K, 4000K, 6500K
Luminous Flux	2000 Lm or 4000 Lm
Beam Angle	110°
Type of Distribution	Direct Symmetrical
Efficiency	100 Lm/W

#### PHYSICAL DATA

Finish	Black/White
Protection Level - IP	IP20
Dimensions (20W)	600x50x70 mm
Dimensions (40W)	1200x50x70 mm
Type of Installation	3 Type of Installation
Body Frame	Aluminium
Optical Material	PMMA

#### ELECTRICAL DATA

Input Power	20W or 40W
Driver Type	Isolated Driver
Operating Voltage	100-277 V
Frequency	50-60 Hz
CRI	80
Operation Temperature	-20°C to +40°C

#### DIMENSIONS

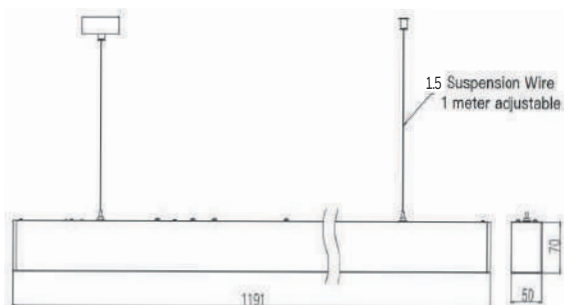

Select one of the following 3 installation methods :

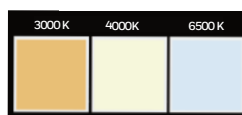

(CCT) Color Temperature Switch



#### ADDITIONAL INFORMATION

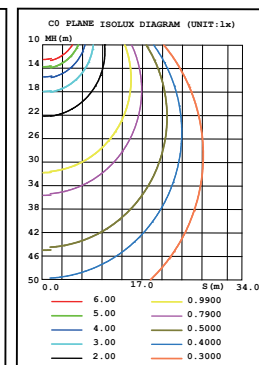
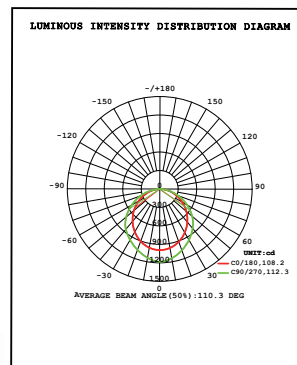

**THE MEASURE OF A PRO™**

## LED LINEAR LIGHT

### SXIMSST01



LED accessories for linear lighting fixtures. Aluminum connection modules designed to create L, T and X configurations for LED linear luminaires. Provide seamless continuity, uniform illumination, and modern architectural aesthetics. Easy to install and connect, with CCT switch (3000K/4000K/6500K). Ideal for commercial and professional lighting systems.

#### FEATURES

- Aluminum extruded body with durable finish
- CCT color Selection 3000K / 4000K / 6500K
- Surface ceiling mounting

#### APPLICATION

- Residential
- Offices
- Showrooms
- Commercial Corridors
- Supermarkets

#### SPECIFICATIONS

Color Temperature(CCT)	3000K,4000K,6500K
Finish	White or Black

#### ELECTRICAL DATA

CRI	80
Protection Level- IP	IP20

#### AVAILABLE OPTIONS

Power	3 CCT Tone	Lumens	Volt	Dimmable / Non Dimmable	Model
20W	3000K,4000K,6500K	2400Lm	100-277V/50-60Hz	Non Dimmable	SXIML01XWH20W
20W	3000K,4000K,6500K	2400Lm	100-277V/50-60Hz	Non Dimmable	SXIML01XBK20W
20W	3000K,4000K,6500K	2400Lm	100-277V/50-60Hz	Non Dimmable	SXIML01TWH20W
20W	3000K,4000K,6500K	2400Lm	100-277V/50-60Hz	Non Dimmable	SXIML01TBK20W
20W	3000K,4000K,6500K	2400Lm	100-277V/50-60Hz	Non Dimmable	SXIML01LWH20W
20W	3000K,4000K,6500K	2400Lm	100-277V/50-60Hz	Non Dimmable	SXIML01LBK20W

#### DIMENSIONS

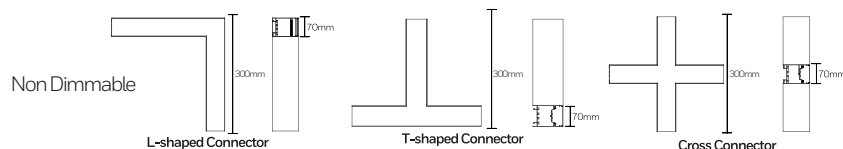

#### LUMINOUS INTENSITY DISTRIBUTION

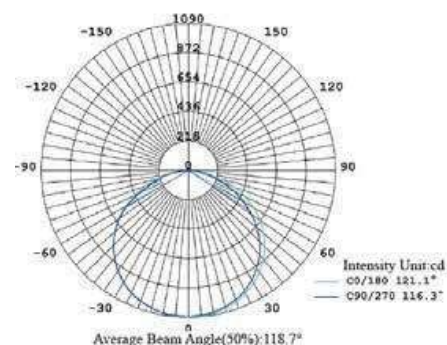

**THE MEASURE OF A PRO™**

## LED LINEAR LIGHT CCT

### SXIML02-PSCCT



LED Linear luminaire, homogeneous light distribution without shadows, for a continuous, clean and simple lighting system. Modern and compact design with LED strip and opalized diffuser.  
With 3 installation methods: pendant, surface-mounted, or recessed/Trimless

#### FEATURES

- 3 Color Switchable Selection 3000K/4000K/6500K.
- 1.5 Mt Pendant Kit Adjustable.
- Ability to operate in cold conditions.
- Upper plug (**optional**) & play accessory for up light.
- General lighting for limited build-in height.
- Instant lighting and the ability to withstand frequent switching.

#### APPLICATION

- Offices
- Commercial Areas
- Stores
- Educational Institutions

Indoor



Multi Color Temperature (CCT)



Eco Friendly



3 Type of Installation

Hanging, Surface & Recessed



LED

#### OPTICAL DATA

Color Temperature (CCT)	3000K, 4000K, 6500K
Luminous Flux	100 Lm
Beam Angle	110°
Type of Distribution	Direct Symmetrical
Upper Plug ( <b>Optional</b> )	
Upper Light	16W
Down Light	24W

#### PHYSICAL DATA

Finish	Black/White
Protection Level - IP	IP20
Dimensions	1200x50x70 mm
Type of Installation	3 Type of Installation
Body Frame	Aluminium
Optical Material	PC

#### ELECTRICAL DATA

Input Power	40W
Driver Type	Isolated Driver
Operating Voltage	100-277 V
Frequency	50-60 Hz
CRI	80
Operation Temperature	-20°C to +40°C

#### DIMENSIONS

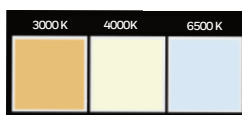
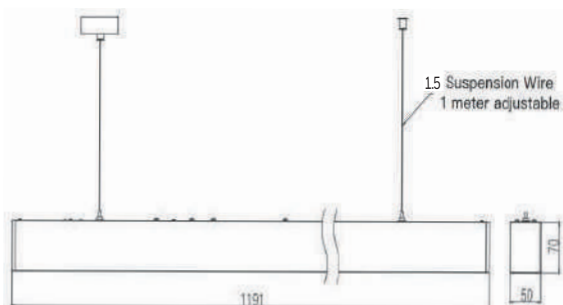

(CCT) Color Temperature Switch

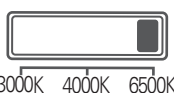

Select one of the following 3 installation methods :

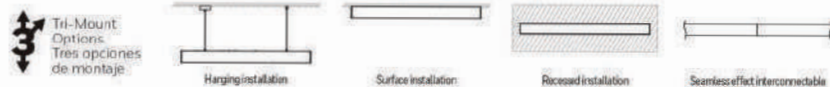

#### ADDITIONAL INFORMATION

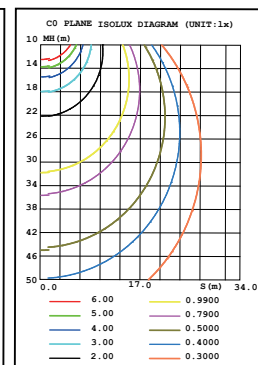
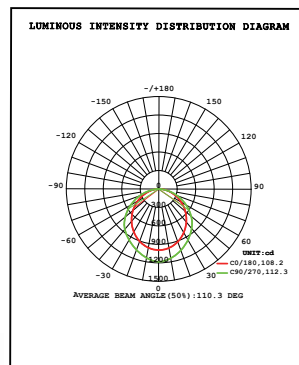

**THE MEASURE OF A PRO™**

# STANLEY

## LED PANEL LIGHT 1x4

### SXIMP1X4-01-CCT

Backlit Panel Certified, with high uniform lighting performance. CCT selectable Switch.

#### FEATURES

- Backlit design without LGP, No risk of yellowing.
- Energy efficiency: THD>20%
- No UV emissions
- High light uniformity
- 3 CCT Selectable: 3000K, 4000K, 6000K could be adjusted with a switch

#### APPLICATION

- Classroom
- Office
- Meeting Room
- Shopping Mall
- Commercial Areas
- Hospitality and retail areas

Indoor



LED



Life Span  
50,000 H



Multi Color  
Temperature  
(CCT)



Easy  
Installation



Save Money

#### OPTICAL DATA

Color Temperature (CCT)	3000K, 4000K, 6000K
CCT Switchable	YES
Luminous Flux	4000,4700,4450 Lm
Type of Distribution	Direct Symmetrical
Beam Angle	120°
Efficiency	117 Lm/W
Life Span	50 000 Hrs

#### PHYSICAL DATA

Finish	White
Protection Level - IP	IP20
Dimensions (LxWxH)	295x1195x34 mm
Type of Installation	Recessed or Pendant
Body Frame	Aluminium
Optical Material	Diffuser PS
Operation Temperature	0°C to +40°C

#### ELECTRICAL DATA

Input Power	40W
Operating Voltage	120-277 V
Frequency	50-60 Hz
Power Rating	>0.90
CRI	80
Dimmable	NO

#### DIMENSIONS

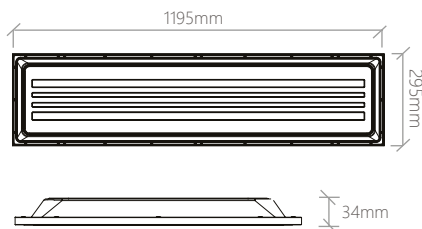

This panel can be installed in two different ways: Pendant or recessed.

#### LUMINOUS INTENSITY DISTRIBUTION

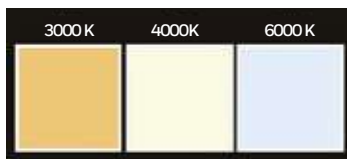
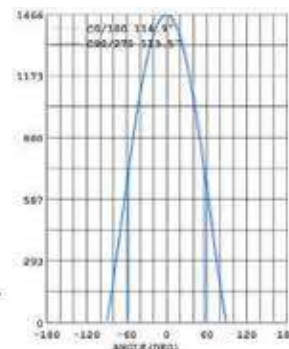
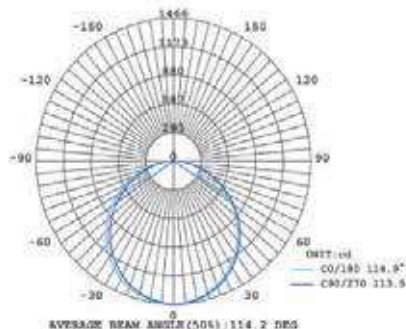

(CCT) Color Temperature Switch

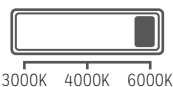

THE MEASURE OF A PRO™

# STANLEY®

## LED PANEL LIGHT 2x2

### SXIMP2X2-01-CCT

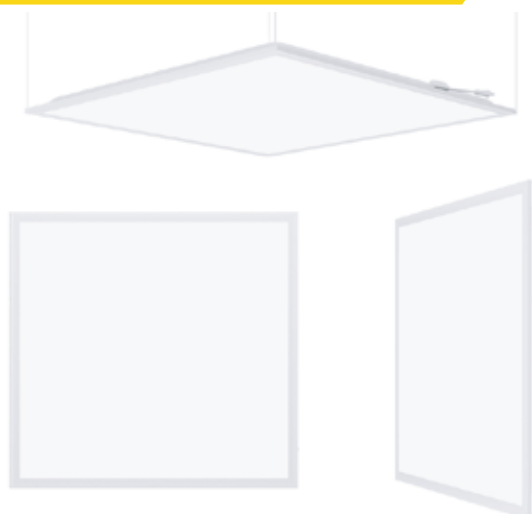

Backlit Panel Certified, with high uniform lighting performance. CCT selectable switch.

#### FEATURES

- Backlit design without LGP, No risk of yellowing.
- THD>20%
- Energy efficiency
- Long Lifespan
- No UV emissions
- High uniform lighting
- 3 CCT Selectable: 3000K, 4000K, 6000K could be adjusted with a switch

#### APPLICATION

- Classroom
- Office
- Meeting Room
- Shopping Mall
- Commercial Areas
- Hospitality and retail areas



Multi Color Temperature (CCT)



Easy Installation



Save Money



Life Span 50,000 H

#### OPTICAL DATA

Color Temperature (CCT)	3000K, 4000K, 6000K
CCT Switchable	YES
Luminous Flux	4100, 4700, 4500Lm
Type of Distribution	Direct Symmetrical
Beam Angle	120°
Efficiency	117Lm/W
Life Span	50 000 Hrs

#### PHYSICAL DATA

Finish	White
Protection Level - IP	IP20
Dimensions (LxWxH)	595x595x34mm
Type of Installation	Recessed or Pendant
Body Frame	Aluminium
Optical Material	Diffuser PS
Operation Temperature	00°C to +40°C

#### ELECTRICAL DATA

Input Power	40W
Operating Voltage	120-277 V
Frequency	50-60 Hz
Power Rating	>0.90
CRI	80
Dimmable	NO

#### DIMENSIONS

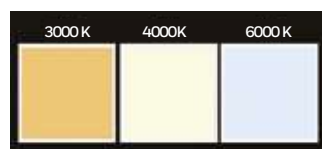
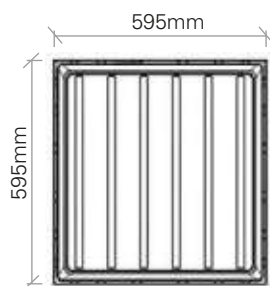

(CCT) Color Temperature Switch

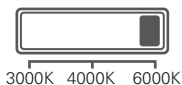

#### LUMINOUS INTENSITY DISTRIBUTION

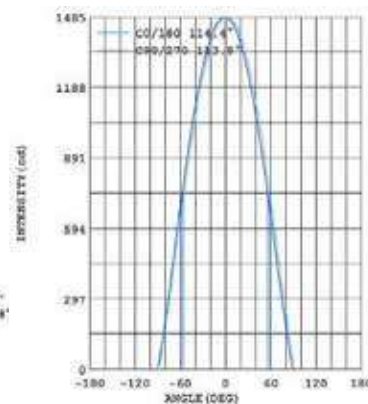
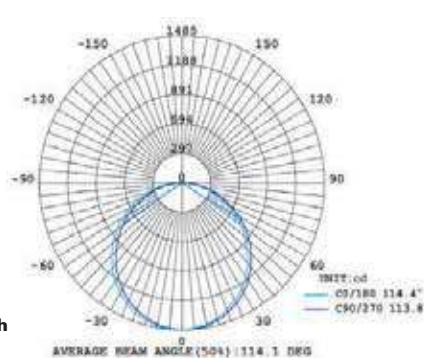

## THE MEASURE OF A PRO™

## LED SURFACE PANEL LIGHT

### SXIM-P2X4-01-CCT

Backlit Panel Certified, with high uniform lighting performance. CCT selectable switch.



#### FEATURES

- Backlit design without LGP, No risk of yellowing.
- Energy efficiency
- THD>20%
- No UV emissions
- High uniform lighting
- 3 CCT Selectable: 3000K, 4000K, 6000K could be adjusted with a switch

#### APPLICATION

- Classroom
- Office
- Meeting Room
- Shopping Mall
- Commercial Areas
- Hospitality and retail areas



## LED



OPTICAL DATA		PHYSICAL DATA		ELECTRICAL DATA	
Color Temperature (CCT)	3000K,4000K, 6000K	Finish	White	Input Power	60W
CCT Switchable	YES	Protection Level - IP	IP20	Operating Voltage	120-277 V
Luminous Flux	6600 ,7400,7000Lm	Dimensions (LxWxH)	1195x595x34mm	Frequency	50-60 Hz
Type of Distribution	Direct Symmetrical	Type of Installation	Recessed or Pendant	Power Rating	>0.90
Beam Angle	120°	Body Frame	Aluminium	CRI	80
Efficiency	117 Lm / W	Optical Material	Diffuser PS	Dimmable	NO
Life Span	50 000 Hrs	Operation Temperature	0°C to +40°C		

#### DIMENSIONS

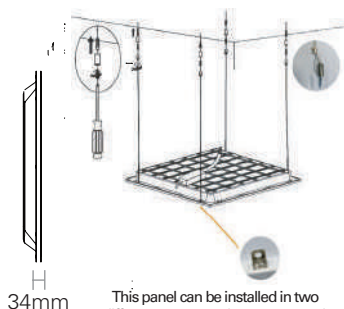
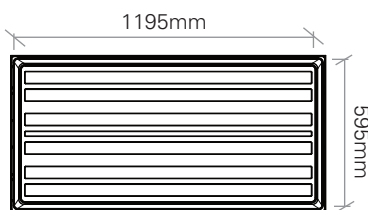

This panel can be installed in two different ways: pendant or recessed.



(CCT) Color Temperature Switch

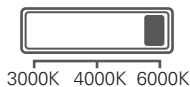

#### LUMINOUS INTENSITY DISTRIBUTION

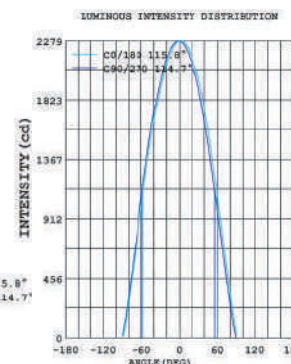
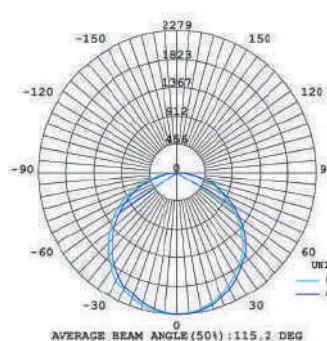

## THE MEASURE OF A PRO™

# STANLEY

## LED PANEL LIGHT

### SXIMP2X2-02-UL

Backlite panel UL Certified, with high uniform lighting performance. watt and CCT selectable.

#### FEATURES

- ANSI C82.77-2002 Surge Protector
- THD<20%
- Excellent surface treatment.
- Light in weight and more like traditional grille light, better for user experience.
- Backlit design without LGP, No risk of yellowing.
- Fully Automated production lines guarantees short lead time.
- 3 CCT Selectable: 3500K, 4000K, 5000K could be adjusted with a switch

#### APPLICATION

Classroom      Shopping Mall  
Office          Commercial Areas  
Meeting Room    And others



Indoor



RoHS



#### OPTICAL DATA

Color Temperature (CCT)	3500K, 4000K, 5000K
CCT Switchable	YES
Luminous Flux	5330 lm
Type of Distribution	Direct Symmetrical
Beam Angle	120°
Efficiency	150 Lm/W
Life Span	50 000 Hrs

#### PHYSICAL DATA

Finish	White
Protection Level - IP	IP20
Dimensions (LxWxH)	604x604x38mm
Type of Installation	Recessed or Pendant
Body Frame	Aluminium
Optical Material	Diffuser PC
Operation Temperature	-20°C to +40°C

#### ELECTRICAL DATA

Input Power	20W, 30W, 35W
Power Switchable	YES
Operating Voltage	120-277 V
Frequency	50-60 Hz
Power Rating	>0.90
CRI	80
Dimmable	0-10V

#### DIMENSIONS

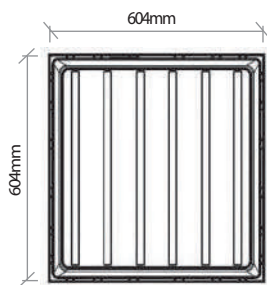

This panel can be installed in two different ways: Pendant or recessed.

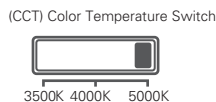
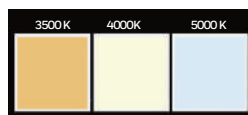

#### LUMINOUS INTENSITY DISTRIBUTION

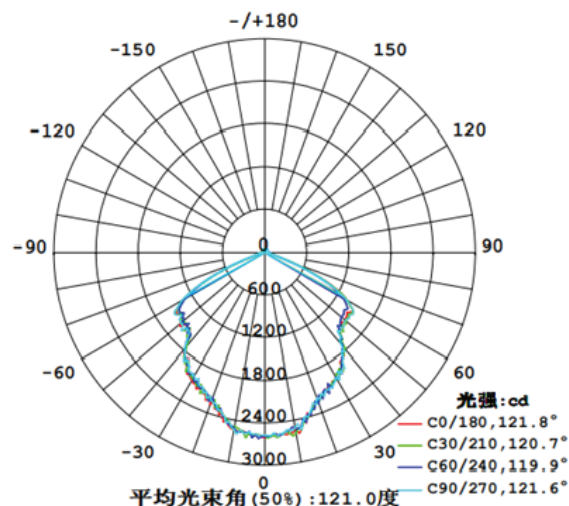

## THE MEASURE OF A PRO™

# STANLEY

## LED PANEL LIGHT

### SXIMP2X4-02-UL



Indoor

Backlit Panel UL Certified, with high uniform lighting performance. CCT selectable switch.

#### FEATURES

- Backlit design without LGP, No risk of yellowing.
- ANSI C82.77-2002 Surge Protector
- THD<20%
- Energy efficiency
- No UV emissions
- High light uniformity
- 3 CCT Selectable: 3500K, 4000K, 5000K could be adjusted with a switch

#### APPLICATION

- Classroom
- Office
- Meeting Room
- Shopping Mall
- Commercial Areas
- Hospitality and retail areas



RoHS



Multi Color Temperature (CCT)



Multi Wattage Switchable

#### OPTICAL DATA

Color Temperature (CCT)	3500K, 4000K, 5000K
CCT Switchable	YES
Luminous Flux	4260/4390/6090 Lm
Type of Distribution	Direct Symmetrical
Beam Angle	120°
Efficiency	135 Lm/W
Life Span	50 000 Hrs

#### PHYSICAL DATA

Finish	White
Protection Level - IP	IP20
Dimensions (LxWxH)	1214x604x38mm
Type of Installation	Recessed or Pendant
Body Frame	Aluminium
Optical Material	Diffuser PC
Operation Temperature	-20°C to +40°C

#### ELECTRICAL DATA

Input Power	30W, 35W, 45W
Power Switchable	YES
Operating Voltage	120-277 V
Frequency	50-60 Hz
Power Rating	>0.90
CRI	80
Dimmable	0-10V

#### DIMENSIONS

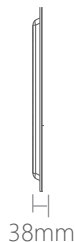
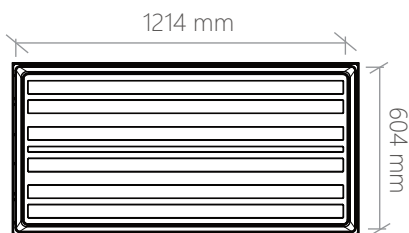

This panel can be installed in two different ways: pendant or recessed.

#### LUMINOUS INTENSITY DISTRIBUTION

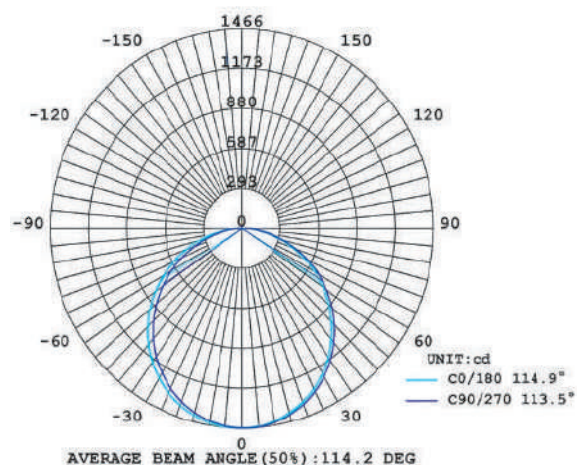

(CCT) Color Temperature Switch

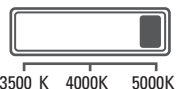

Power Selectable Switch

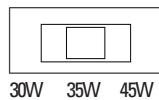

## THE MEASURE OF A PRO™

# STANLEY

## LED STREET LIGHT CCT

### SXIMST-01-PSCCT



LED luminaire for street and outdoor lighting, modern and compact design, uniform light projection, high efficiency, long life and easy installation, reduces energy consumption and maintenance costs.

#### FEATURES:

- Heavy Duty Die Cast aluminum housing with ample heat sinking.
- Angle of inclination adjustable in  $\pm 90^\circ$ .
- Slipfit Arm included.
- IP65/IK08/4KV Rating.
- Long Lifespan.

#### APPLICATION

- Park
- Square
- Trails
- Public or Private roads
- Parking lot
- Bridges
- Residential Buildings
- Others



CE IP65

PHOTOCELL SENSOR



Multi Color Temperature (CCT)



Multi Wattage Switchable



Water Proof

#### OPTICAL DATA

Color Temperature (CCT)	4000K, 5000K, 6000K
Lumens	16,856 lm/24,359 lm/30,455lm
Beam Angle	80x150° Type III
Type of Distribution	Direct Symmetrical
Life Span	50 000 H
Optical Material	Diffuser PC

#### PHYSICAL DATA

Finish	Black
Protection Level - IP	IP65
Dimensions (LxWxH)	300x 438x 62mm
Body Frame	Die -Cast Aluminium
Weight	5.22 kg
Operation Temperature	-40°C to +50°C

#### ELECTRICAL DATA

Input Power	100W, 150W, 200W
Power Switchable	YES
Operating Voltage	120-277 V
Frequency	50-60 Hz
Power Factor	>0.95
CRI	70

#### DIMENSIONS

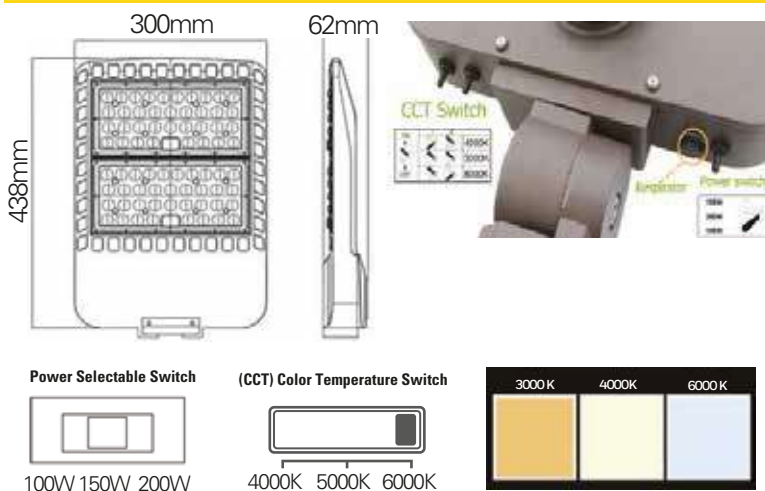

#### ADDITIONAL INFORMATION

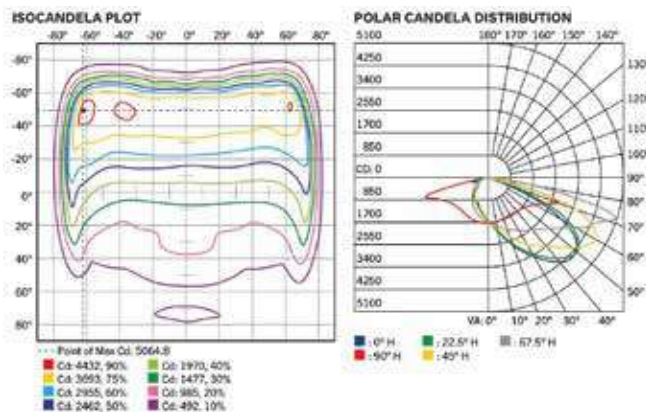

**THE MEASURE OF A PRO™**

# STANLEY

## LED STREET LIGHT CCT

### SXIMST01-100WCT



High-performance LED street light with integrated photocell sensor and 3CCT selectable technology. Designed for roadway, parking lot, and outdoor area illumination.

#### FEATURES:

- Integrated Photocell Sensor (Auto ON/OFF)
- 3CCT Selectable: 4000K / 5000K / 6000K
- Type III Light Distribution
- High Efficiency: 140-150 lm/W
- Wide Voltage Range: 120-277 VAC
- Slipfitter Arm A-C Included
- Suitable for Wall Mount & Pole Mount
- Durable Dark Bronze Finish

#### APPLICATION

- Roadways
- Parking Lots
- Perimeter Lighting
- Industrial Facilities
- Commercial Outdoor Areas



# IP65



Multi Color Temperature (CCT)

PHOTOCELL SENSOR



#### OPTICAL DATA

Color Temperature (CCT)	4000K, 5000K, 6000K
Lumens	140-150 Lm/W
Beam Angle	80x150°
Type of Distribution	Direct Symmetrical
Life Span	50 000 Hrs
Optical Material	Diffuser PC

#### PHYSICAL DATA

Finish	Black
Protection Level - IP	IP65
Dimensions (LxVxH)	275x268x47 mm
Body Frame	Die -Cast Aluminium
Operation Temperature	-40°C to +50°C
Mounting Options	Slipfitter Arm A-C
(Wall Mount & Pole Mount Compatible)	

#### ELECTRICAL DATA

Input Power	100W
Power Switchable	YES
Operating Voltage	120-277 V
Frequency	50-60 Hz
Power Factor	>0.95
CRI	70

#### DIMENSIONS

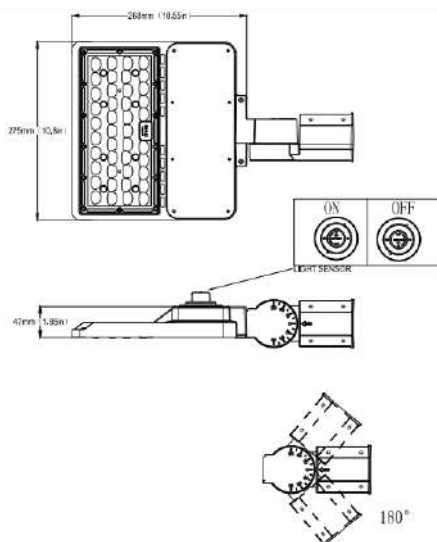

#### (CCT) Color Temperature Switch

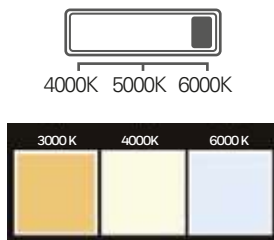

#### ADDITIONAL INFORMATION

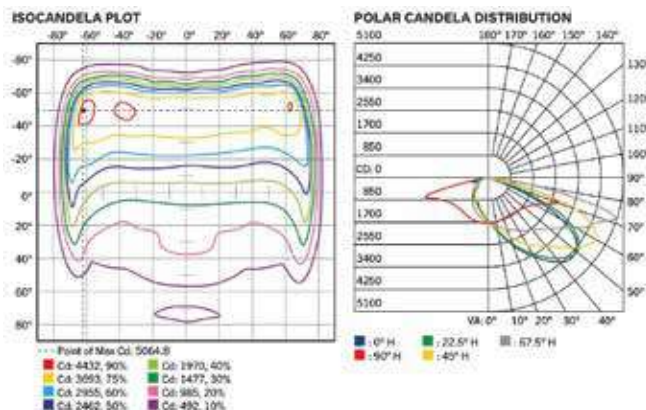

**THE MEASURE OF A PRO™**

# STANLEY

## LED STREET LIGHT CCT

### SXIMST01-200WCT



High-performance 200W LED street light with integrated photocell sensor and 3CCT selectable technology. Designed for roadways, highways, parking lots, and large outdoor areas requiring high lumen output.

#### FEATURES:

- Integrated Photocell Sensor (Auto ON/OFF)
- 3CCT Selectable: 4000K / 5000K / 6000K
- Type III Light Distribution
- High Efficiency: 140-150 lm/W
- Wide Voltage Range: 120-277 VAC
- Slipfitter Arm A-C Included
- Compatible with Wall Mount & Pole Mount
- Durable Dark Bronze Finish

#### APPLICATION

- Highways
- Main Roads
- Large Parking Areas
- Industrial Complexes
- Commercial Outdoor Areas



# IP65



Multi Color Temperature (CCT)

PHOTOCELL SENSOR



#### OPTICAL DATA

Color Temperature (CCT)	4000K, 5000K, 6000K
Lumens	140-150 Lm/W
Beam Angle	80x150°
Type of Distribution	Direct Symmetrical
Life Span	50 000 Hrs
Optical Material	Diffuser PC

#### PHYSICAL DATA

Finish	Black
Protection Level - IP	IP65
Dimensions (LxVxH)	300x300x72 mm
Body Frame	Die -Cast Aluminium
Operation Temperature	-40°C to +50°C
Mounting Options	Slipfitter Arm A-C
(Wall Mount & Pole Mount Compatible)	

#### ELECTRICAL DATA

Input Power	200W
Power Switchable	YES
Operating Voltage	120-277 V
Frequency	50-60 Hz
Power Factor	>0.95
CRI	70

#### DIMENSIONS

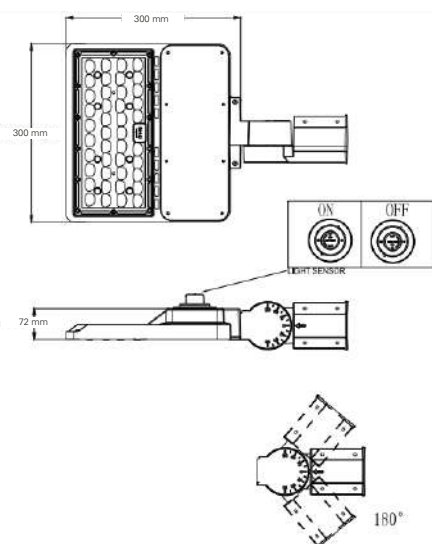

(CCT) Color Temperature Switch

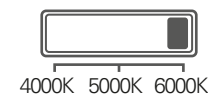

#### ADDITIONAL INFORMATION

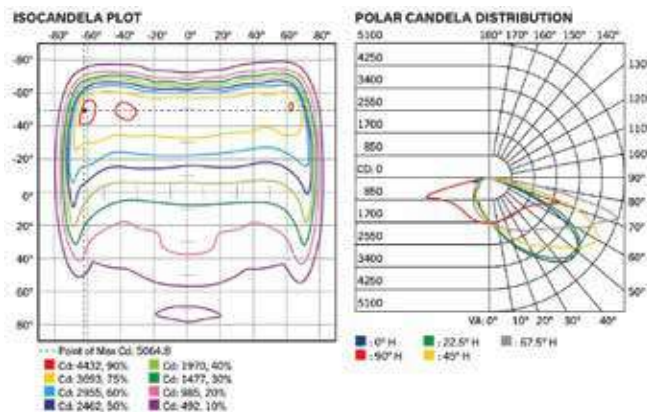

**THE MEASURE OF A PRO™**

# STANLEY®

## LED TRI-PROOF LIGHT CCT

### SXIMTRI01-18WCT/36WCT



High-performance waterproof LED tri-proof tube with PC + Aluminum housing. Designed for industrial and commercial environments requiring durability and efficiency.

#### FEATURES

- PC + Aluminum Waterproof Construction
- IP65 Protection
- 3CCT Selectable (3000K / 4000K / 6500K)
- Surface Mounted Installation
- High Durability for Industrial Use
- Corrosion Resistant Housing

#### APPLICATION

- Warehouses
- Parking Areas
- Industrial Facilities
- Commercial Buildings
- Humid Environments



**LED**

**IP65**



OPTICAL DATA		PHYSICAL DATA		ELECTRICAL DATA	
Color Temperature (CCT)	3000K, 4000K, 6500K	Finish	White	Operating Voltage	100-277V
Beam Angle	120°	Protection Level - IP/IK	IP65	Frequency	50-60 Hz
Type of Distribution	Direct Symmetrical	Type of Installation	Ceiling Mountable	Power Rating	> 0.50
Luminous Flux	1800 lm (18W model)	Body Frame	PC+Aluminum	CRI	80
	3600 lm (36W model)	Dimensions	0.6m (18W)	Input Power	18W
			1.2m (36W)		36W

#### DIMENSIONS

SXIMTRI01-18WCT

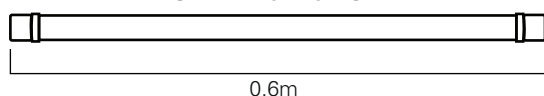

0.6m

SXIMTRI01-36WCT

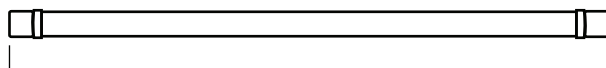

1.2m

(CCT) Color Temperature Switch



4000K 5000K 6500K



#### LUMINOUS INTENSITY DISTRIBUTION

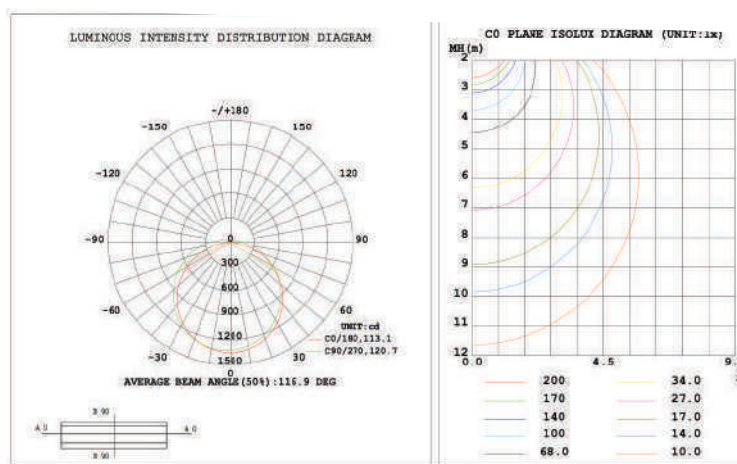

## THE MEASURE OF A PRO™

# STANLEY

## LED TRI-PROOF LIGHT

### SXIMTRI02-PS-CCT

High-performance industrial LED luminaire with multi-wattage and 3CCT selectable technology. Designed for commercial and industrial applications requiring flexibility and efficiency.

#### FEATURES

- 4-Level Power Selectable: 35W / 42W / 50W / 60W
- 3CCT Selectable: 3000K / 4000K / 6500K
- Wide Voltage Range: AC100-277V
- High efficiency LED system
- Durable industrial construction
- Surface mounting installation

#### APPLICATION

- Industrial Areas
- Sidewalks
- Parks
- Schools
- And Others

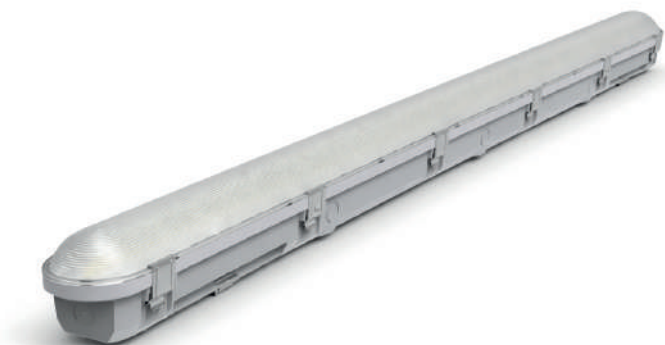

LED



Multi Wattage Switchable



Eco Friendly

UV Protection



Easy Installation

#### OPTICAL DATA

Color Temperature (CCT)	3000K, 4000K, 6500K
Luminous Flux	6870 Lm, 6000Lm
	5109 Lm, 4092Lm
Beam Angle	120°
Type of Distribution	Direct Symmetrical
Opening Angle	80

#### PHYSICAL DATA

Finish	Gray & White
Protection Level - IP	IP65
Dimensions (LxWxH)	1200x96x83mm
Type of Installation	Surface Mounted
Body Frame	PC
Optical Material	Diffuser PC
Operation Temperature	-20°C to +40°C

#### ELECTRICAL DATA

Input Power	35W, 42W, 50W, 60W
Power Switchable	YES
Operating Voltage	100-277 V
Frequency	50-60 Hz
Power Factor	>0.9
CRI	80
Dimmable	NO

#### DIMENSIONS

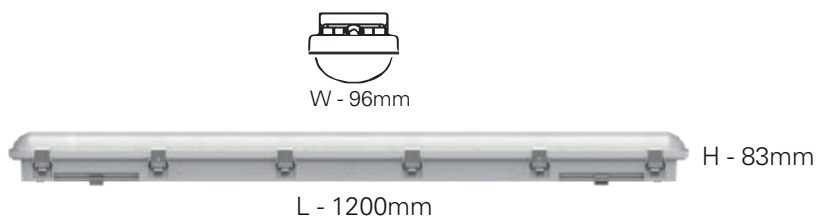

(CCT) Color Temperature Switch

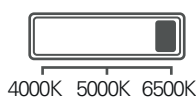

#### LUMINOUS INTENSITY DISTRIBUTION

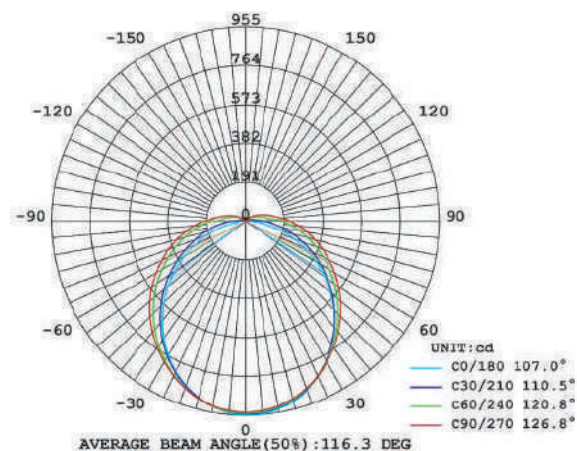

THE MEASURE OF A PRO™

# STANLEY

## LED TRI-PROOF LIGHT

### SXIMTRI03-PS-65K



Hermetic industrial luminaire, clipless design, smooth and elegant appearance, no need to open the diffuser to connect with safe and reliable protection level  
Switchable power: 30W, 40W or 50W.

#### FEATURES

- UV protection
- Built in high luminous efficiency LED Chip and Driver
- IP65/IK08
- 3 Level Power Switchable
- Fast connection
- Light Efficiency: 100-118lm/W

#### APPLICATION

- Industrial Areas
- Schools
- Sidewalks
- And Others
- Parks



LED



Multi Wattage Switchable



Eco Friendly

UV Protection



Easy Installation

#### OPTICAL DATA

Color Temperature (CCT)	6500K
Luminous Flux	3540,4280,5170 Lm
Beam Angle	120°
Type of Distribution	Direct Symmetrical
Opening Angle	80
Efficiency	100-118 Lm /W

#### PHYSICAL DATA

Finish	Gray & White
Protection Level - IP	IP65
Dimensions (LxWxH)	1200x70x56 mm
Type of Installation	Surface Mounted
Body Frame	PC
Optical Material	Diffuser PC
Operation Temperature	-20°C to +40°C

#### ELECTRICAL DATA

Input Power	30W, 40W, 50W
Power Switchable	YES
Operating Voltage	100-277 V
Frequency	50-60 Hz
Power Factor	>0.9
CRI	80
Dimmable	NO

#### DIMENSIONS



W - 70mm



H - 56mm



L - 1200mm



30W 40W 50W

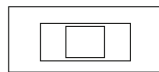

Power Selectable Switch

#### LUMINOUS INTENSITY DISTRIBUTION

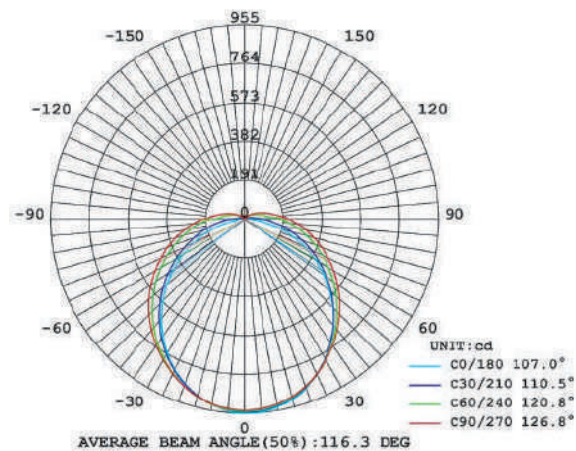

**THE MEASURE OF A PRO™**

# STANLEY®

## LED TRI-PROOF LIGHT

### SXIMTRI04-18W65K/36W65K



The LED Tri-Proof Light IP20 is a reliable and efficient indoor lighting solution designed for durability and performance. With selectable power options of 18W and 36W, and a consistent light color temperature of 6500K, it provides bright, uniform illumination ideal for commercial and residential spaces.

#### FEATURES

- High luminous efficiency LED chip and driver.
- Available in 18W and 36W.
- Fixed CCT: 6500K daylight.
- Long lifespan, energy-saving, eco-friendly.

#### APPLICATION

- Residential Areas • Schools
- Retail stores and supermarkets. • And others



**LED**



Indoor



Save Money



Easy Installation



Eco Friendly

#### OPTICAL DATA

Color Temperature (CCT)	6500K
Beam Angle	120°
Type of Distribution	Direct Symmetrical

TRI-04-18W	TRI-04-36W
<b>Luminous Flux</b>	
2000 lm	4000 lm

#### PHYSICAL DATA

Finish	White
Protection Level - IP/IK	IP20
Type of Installation	Ceiling Mountable
Body Frame	PC
Optical Material	Diffuser PC
Operation Temperature	-20°C to +40°C

TRI-04-18W	TRI-04-36W
<b>Dimensions</b>	
600 X 75 X 25mm	1200 X 75 X 25mm

#### ELECTRICAL DATA

Operating Voltage	100-277V
Frequency	50-60 Hz
Power Rating	> 0.50
CRI	80

TRI-04-18W	TRI-04-36W
<b>Input Power</b>	
18W	36W

#### DIMENSIONS

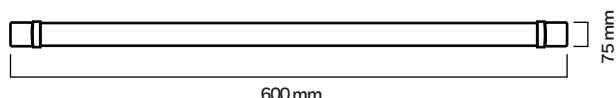

TRI-04-18

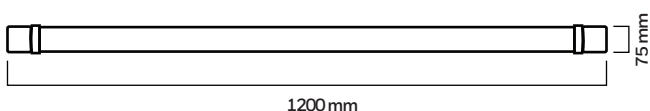

TRI-04-36

#### LUMINOUS INTENSITY DISTRIBUTION

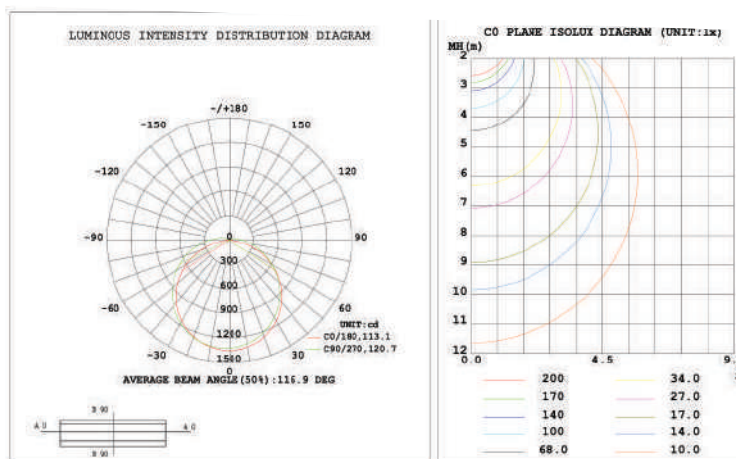

## THE MEASURE OF A PRO™

# STANLEY®



## **EXTENSION CORDS & POWER STRIPS**

©2026 Stanley Black & Decker, Inc. Stanley® and the Stanley/ logo are trademarks of Stanley Black & Decker, Inc. or an affiliate thereof and are used under license. Manufactured by Lighting & Hardware Distribution Inc., Panama Headquarters, 1 (888) 502-8432, [www.lightingandhardware.com](http://www.lightingandhardware.com)

# STANLEY®

## INDOOR & OUTDOOR HEAVY DUTY EXTENSION CORD

### SXIM-E-01



#### BENEFITS:

- Extend range of outlets.
- Useful for light to medium duty items.
- Easy to install and move.
- They allow you to use tools in the workshop.
- Ideal for landscaping.
- Long lifespan.

#### HIGHLY VISIBLE

Yellow jacket provides extra safety and prevents tripping while working in the yard.

#### COMMON USES

Ideal for landscaping and powering appliances such as a shop vac, weed wacker, bush trimmer, leaf blower and electric lawn mower.



#### AVAILABLE OPTIONS

SXIM-E-01-25FT

SXIM-E-01-50FT

SXIM-E-01-100FT

#### ENERGY INFORMATION

	SXIM-E-01-25FT	SXIM-E-01-50FT	SXIM-E-01-100FT
Max Power:	1625W	1625W	1250W
Voltage/Hz:	125V / 50-60HZ	125V / 50-60HZ	125V / 50-60HZ
Current:	13A	13A	10A

#### DIMENSIONS



#### ADDITIONAL INFORMATION

No. of Outlet Plug:	1
Finish:	Yellow
Certificate:	ETL
Specification:	16 GAUGE / 3-pronged
Material:	Copper, PVC
Size:	25/50/100 ft



## THE MEASURE OF A PRO™

# STANLEY®

## EXTENSION CORD

### SXIM-E-02



**25'**  
FEET

**50'**  
FEET

**100'**  
FEET

#### BENEFITS:

- Extends range of outlets.
- Ideal for light to medium duty applications.
- Flexible and durable cable jacket.
- Easy to install and move.
- Provides safe and stable power connection.
- Long service lifespan.

#### HIGHLY VISIBLE

Yellow jacket provides extra visibility and safety, reducing tripping risks in work areas, construction sites, and outdoor environments.

#### COMMON USES

Ideal for powering light-duty appliances and tools such as:

- Home equipment
- Garden tools
- Power tools
- Shop vacs
- Leaf blowers
- Weed trimmers
- Indoor & outdoor temporary connections.



#### AVAILABLE OPTIONS

SXIM-E-02-25FT

SXIM-E-02-50FT

SXIM-E-02-100FT

#### ENERGY INFORMATION

	SXIM-E-02-25FT	SXIM-E-02-50FT	SXIM-E-02-100FT
Max Power:	1625W	1625W	1250W
Voltage/Hz:	125V / 50-60HZ	125V / 50-60HZ	125V / 50-60HZ
Current:	13A	13A	10A

#### DIMENSIONS

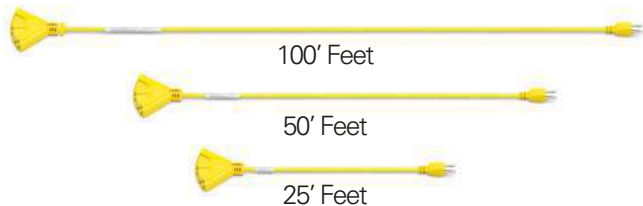

#### ADDITIONAL INFORMATION

No. of Outlet Plug:	3
Certificate:	ETL
Specification:	16 GAUGE / 3-pronged
Material:	Copper, PVC
Finish:	Yellow
Size:	25/50/100 ft



## THE MEASURE OF A PRO™

# STANLEY

## POWER STRIP WITH LIGHTED SWITCH ON/OFF

**SXIM-E-03**



### BENEFITS:

- 8 grounded outlets for extended connectivity.
- Ideal for home, office, garage or workshop use.
- Easy wall mounting with horizontal or vertical keyholes.
- Compact and practical design.
- ETL certified for safety and reliability.

### 8 OUTLETS

Industrial-style design with 8 total outlets. Optimized spacing allows connection of multiple plugs at once. Heavy-duty cord for reliable performance.

### COMMON USES

Perfect for powering multiple devices such as:

- Power tools
- Computers and office equipment
- Home appliances
- Garage or workshop equipment



### AVAILABLE OPTIONS

SXIM-E-03

### ENERGY INFORMATION

Voltage/Hz:	125V / 50-60Hz
Current:	15A
Surge Protect:	300J

### ADDITIONAL INFORMATION

No. of Outlet Plug:	8 Outlets
Finish:	White
Specification:	14AWG * 3C / SJT / 3FT
Certificate:	ETL
Material:	Copper, Plastic



**THE MEASURE OF A PRO™**

# STANLEY

## WALL TAP

### SXIM-E-04

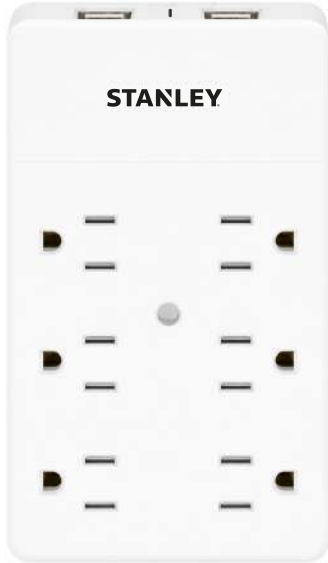

#### BENEFITS:

- 6 grounded AC outlets for multiple devices.
- Integrated USB-A and USB-C fast charging ports.
- 1200 Joules surge protection for enhanced safety.
- Ideal for home, office and workstation setups.
- ETL certified for electrical safety.
- Space-saving vertical design.

#### OUTLET CONFIGURATION

- 6 grounded 3-prong AC outlets.
- 2 USB-A port.
- 1 USB-C port.

Optimized spacing allows multiple plugs simultaneously.

#### OUTLET CONFIGURATION

USB-A Output: 5Vdc 2.4A

USB-C Output: 5Vdc 3.0A

USB-A + USB-C (simultaneous use): 5Vdc 3.4A total



#### AVAILABLE OPTIONS

SXIM-E-04

#### ENERGY INFORMATION

Max Power: 1875W

Voltage/Hz: 125V / 50-60Hz

Current: 15A

Surge Protect: 1200J

#### ADDITIONAL INFORMATION

No. of Outlet Plug: 6 Outlets

USB Ports: 2 USB-A + 1 USB-C

Finish: White

Certificate: ETL

Material: Copper, Plastic



**THE MEASURE OF A PRO™**

# STANLEY®

## POWER STRIP WITH LIGHTED SWITCH ON/OFF

**SXIM-E-05**



### BENEFITS:

- 12 grounded outlets for extended connectivity.
- Ideal for home, office, garage or workshop use.
- Easy wall mounting with horizontal or vertical keyholes.
- Compact and practical design.
- ETL certified for safety and reliability.

### 12 OUTLETS

Industrial-style design with 12 total outlets. Optimized spacing allows connection of multiple plugs at once. Heavy-duty cord for reliable performance.

### COMMON USES

Perfect for powering multiple devices such as:

- Power tools
- Computers and office equipment
- Home appliances
- Garage or workshop equipment



### AVAILABLE OPTIONS

SXIM-E-05

### ENERGY INFORMATION

Voltage/Hz: 125V / 50-60Hz

Current: 15A

### ADDITIONAL INFORMATION

No. of Outlet Plug: 12 Outlets

Finish: Yellow & Black

Specification: 14AWG \* 3C / SJT / 3FT

Certificate: ETL

Material: Iron, Plastic



**THE MEASURE OF A PRO™**

# STANLEY

## POWER STRIP WITH LIGHTED SWITCH ON/OFF

**SXIM-E-06**



### BENEFITS:

- Extend range of outlets.
- Useful for light to medium duty items.
- Easy to install and move.
- Allow to operate multiple tools in the garage or workbench.
- Long lifespan.

### 6 OUTLETS

Industrial look and ruggedly designed with 4 compact outlets and 2 wide spacing outlets. Cord holder design for wrap the cord, with two horizontal or vertical mounting keyholes.

**6**  
OUTLET

**3'**  
FEET

**14**  
GAUGE



### AVAILABLE OPTIONS

SXIM-E-06

### ENERGY INFORMATION

Max Power:	1875W
Voltage/Hz:	125V / 50-60Hz
Current:	15A
Surge Protect:	90J

### ADDITIONAL INFORMATION

No. of Outlet Plug:	6 Outlets
Finish:	Black & Yellow
Specification:	14AWG * 3C / SJT / 3FT
Certificate:	ETL
Material:	Iron, Plastic



**THE MEASURE OF A PRO™**

# STANLEY

## POWER STRIP WITH LIGHTED SWITCH ON/OFF

**SXIM-E-07**



### BENEFITS:

- 8 grounded outlets for extended connectivity.
- Ideal for home, office, garage or workshop use.
- Easy wall mounting with vertical keyholes.
- Compact and practical design.
- ETL certified for safety and reliability.

### 8 OUTLETS

Industrial-style design with 8 total outlets. Optimized spacing allows connection of multiple plugs at once. Heavy-duty cord for reliable performance.

### COMMON USES

Perfect for powering multiple devices such as:

- Power tools
- Computers and office equipment
- Home appliances
- Garage or workshop equipment



### AVAILABLE OPTIONS

SXIM-E-07

### ENERGY INFORMATION

Voltage/Hz:	125V / 50-60Hz
Current:	15A
Surge Protect:	350J

### ADDITIONAL INFORMATION

No. of Outlet Plug:	8 Outlets
Finish:	White
Specification:	14AWG * 3C / SJT / 3FT
Certificate:	ETL
Material:	Copper, Plastic



**THE MEASURE OF A PRO™**

# STANLEY

## POWER STRIP WITH LIGHTED SWITCH ON/OFF

**SXIM-E-08**



### BENEFITS:

- 6 grounded outlets for extended connectivity.
- Ideal for home, office, garage or workshop use.
- Easy wall mounting with vertical keyholes.
- Compact and practical design.
- ETL certified for safety and reliability.

### 6 OUTLETS

Industrial-style design with 6 total outlets. Optimized spacing allows connection of multiple plugs at once. Heavy-duty cord for reliable performance.

### COMMON USES

Perfect for powering multiple devices such as:

- Power tools
- Computers and office equipment
- Home appliances
- Garage or workshop equipment



### AVAILABLE OPTIONS

SXIM-E-08

### ENERGY INFORMATION

Voltage/Hz: 125V / 50-60Hz

Current: 15A

Surge Protect: 90J

### ADDITIONAL INFORMATION

No. of Outlet Plug: 6 Outlets

Finish: White

Specification: 14AWG \* 3C / SJT / 3FT

Certificate: ETL

Material: Copper, Plastic



**THE MEASURE OF A PRO™**

# STANLEY

## POWER STRIP WITH LIGHTED SWITCH ON/OFF

**SXIM-E-09-BK**



### BENEFITS:

- 4 grounded outlets for extended connectivity.
- Ideal for home, office, garage or workshop use.
- Easy wall mounting with vertical keyholes.
- Compact and practical design.
- ETL certified for safety and reliability.

### 4 OUTLETS

Optimized spacing allows connection of multiple plugs at once. Heavy-duty cord for reliable performance.

### COMMON USES

Perfect for powering multiple devices such as:

- Power tools
- Computers and office equipment
- Home appliances
- Garage or workshop equipment



### AVAILABLE OPTIONS

SXIM-E-09-BK

### ENERGY INFORMATION

Voltage/Hz:	125V / 50-60Hz
Current:	15A
Surge Protect:	90J

### ADDITIONAL INFORMATION

No. of Outlet Plug:	4 Outlets
Finish:	Black
Specification:	14AWG * 3C / SJT / 3FT
Certificate:	ETL
Material:	Copper, Plastic



**THE MEASURE OF A PRO™**

# STANLEY

## POWER STRIP WITH LIGHTED SWITCH ON/OFF

### SXIM-E-10



#### BENEFITS:

- 8 grounded AC outlets for multiple devices.
- Integrated USB-A and USB-C fast charging ports.
- Ideal for home, office and workstation setups.
- ETL certified for electrical safety.
- Space-saving vertical design.

#### OUTLET CONFIGURATION

- 8 grounded 3-prong AC outlets.
- 2 USB-A port.
- 1 USB-C port.

#### OUTLET CONFIGURATION

USB-A Output: 5Vdc 2.4A

USB-C Output: 5Vdc 3.0A

USB-A + USB-C (simultaneous use): 5Vdc 3.4A total



#### AVAILABLE OPTIONS

SXIM-E-10

#### ENERGY INFORMATION

Voltage/Hz: 125V / 50-60Hz  
Current: 15A

#### ADDITIONAL INFORMATION

No. of Outlet Plug: 8 Outlets  
USB Ports: 2 USB-A + 1 USB-C  
Finish: White  
Specification: 14AWG \* 3C / SJT / 3FT  
Certificate: ETL  
Material: Copper, Plastic



**THE MEASURE OF A PRO™**

# STANLEY

## POWER STRIP WITH LIGHTED SWITCH ON/OFF

### SXIM-E-13



#### BENEFITS:

Extends the number of available outlets.  
Ideal for light- to medium-duty applications.  
Easy to install and reposition.  
Allows multiple devices to operate at home or in the office.  
Long service life.

#### 6 OUTLETS

This power strip features a lighted ON/OFF switch for easy power status indication (light on when power is on; light off when power is off). The built-in circuit breaker provides overload protection for enhanced safety.

#### COMMON USES

Ideal for entertainment centers, offices, and any space where multiple devices require power.



#### AVAILABLE OPTIONS

SXIM-E-13

#### ENERGY INFORMATION

Max Power	1875W
Voltage/Hz	125V
Current	15A

#### ADDITIONAL INFORMATION

No. of Outlet Plug	6-outlet
Finish	White
Specification	14AWG*3C/SJT
Certification	UL
Size	3 Ft



**THE MEASURE OF A PRO™**

# STANLEY

## POWER STRIP WITH LIGHTED SWITCH ON/OFF

SXIM-E-14



### BENEFITS:

- Extend range of outlets.
- Useful for light to medium duty items.
- Easy to install and move.
- Allow to operate multiple devices at office or home.
- Long lifespan.

### SPACE SAVING

Expanding your outlet can be sleek with this slim outlet adapter wall tap to power your devices.

### POWER MORE

Turn 2 outlets into 6-Outlet Adapter that can power your home or office electronics.



### AVAILABLE OPTIONS

SXIM-E-14

### ENERGY INFORMATION

Max Power	1875W
Voltage/Hz	125V / 50-60Hz
Current	15A

### ADDITIONAL INFORMATION

No. of Outlet Plug	6-outlet
Finish	White
Certificate	ETL



**THE MEASURE OF A PRO™**

# STANLEY®

## 3 OUTLET WALL SURGE PROTECTOR EXTENDER WITH 2 USB PORT

### SXIM-E-15



#### BENEFITS:

- Extends the number of available outlets.
- Ideal for light- to medium-duty devices.
- Easy to install and move.
- Allows multiple devices to operate simultaneously at home or in the office.
- Long service life.

#### 3 SURGE-PROTECTED OUTLETS

This outlet adapter features 3 surge-protected outlets and 2 USB charging ports that share 2.4A output, allowing you to power electronics and charge portable devices conveniently in one place. The 300J surge protection rating helps safeguard your equipment from power surges.

#### MULTI-FUNCTIONAL USB CHARGING STATION

Perfect for charging smartphones, tablets, and other rechargeable devices at home or while traveling.



#### AVAILABLE OPTIONS

SXIM-E-15

#### ENERGY INFORMATION

Max Power:	1875W
Surge Protect:	300J
Voltage/Hz:	125V / 50-60Hz
Current:	15A

#### ADDITIONAL INFORMATION

No. of Outlet Plug:	3 Outlets
Finish:	White
Specification:	2 USB DC5V / 2.4A total
Certificate:	UL
Material:	Copper, Plastic



**THE MEASURE OF A PRO™**

# STANLEY®

## HEAVY DUTY EXTENSION CORD

### SXIM-E-11-50FT



#### BENEFITS:

- Extend range of outlets.
- Useful for light to medium duty items.
- Easy to install and move.
- They allow you to use tools in the or workshops.
- Ideal for landscaping.
- Long lifespan.

#### PRODUCT DESCRIPTION

Heavy-duty extension cord reel designed for safe and convenient indoor power distribution. Ideal for workshops, garages, and home use.

#### COMMON USES

Ideal for landscaping and powering appliances such as a shop vac, weed wacker, bush trimmer, leaf blower and electric lawn mower.



#### AVAILABLE OPTIONS

SXIM-E-11-50FT

#### ENERGY INFORMATION

Max Power: 1250W

Voltage/Hz: 125V / 50-60HZ

Current: 10A

#### ADDITIONAL INFORMATION

No. of Outlet Plug:	4
Finish:	Yellow & Black
Certificate:	ETL, CE
Specification:	14 GAUGE / 3-pronged
Finish:	Copper, ABS
Size Extension Cord:	50 ft



**THE MEASURE OF A PRO™**

# STANLEY®

## INDOOR HEAVY DUTY EXTENSION CORD

### SXIM-E-12-40FT



#### BENEFITS

- 4 grounded outlets for multiple connections.
- Built-in thermal cut-out for overload protection.
- Durable PVC cable jacket for long-lasting performance.
- Compact reel design for easy storage and transport.
- Ideal for home, garage and light-duty workshop use.

#### OUTLET CONFIGURATION

4 grounded outlets (4-way).  
Heavy-duty central hub design.  
Easy cable rewind system.

#### CABLE SPECIFICATION

Cable Type: SJT  
Wire Gauge: 16AWG / 3 Conductors  
Jacket Material: PVC  
Length: 40 ft



#### AVAILABLE OPTIONS

SXIM-E-12-40FT

#### ENERGY INFORMATION

Max Power:	1250W
Voltage/Hz:	125V / 50-60HZ
Current:	10A

#### ADDITIONAL INFORMATION

No. of Outlet Plug:	4
Finish:	Yellow & Black
Certificate:	ETL
Specification:	16 GAUGE / 3-pronged
Finish:	Copper, ABS
Size Extension Cord:	40 ft



**THE MEASURE OF A PRO™**

# STANLEY



## VOLTAGE & SURGE PROTECTORS

©2026 Stanley Black & Decker, Inc. Stanley® and the Stanley/ logo are trademarks of Stanley Black & Decker, Inc. or an affiliate thereof and are used under license. Manufactured by Lighting & Hardware Distribution Inc., Panama Headquarters, 1 (888) 502-8432, [www.lightingandhardware.com](http://www.lightingandhardware.com)

# STANLEY

## VOLTAGE & SURGE PROTECTOR

### SXIM-SP-01



#### PROTECTION FUNCTION

- Over / Under Voltage Protection.
- Phosphor copper parts.
- Flame retardant shell.

#### COMMON USES

A/C up to 60,000BTU, refrigerators, TV's, freezers, washing machines, water cooler, computers, coffee makers, microwaves, electric stoves, and multiple electronic devices.

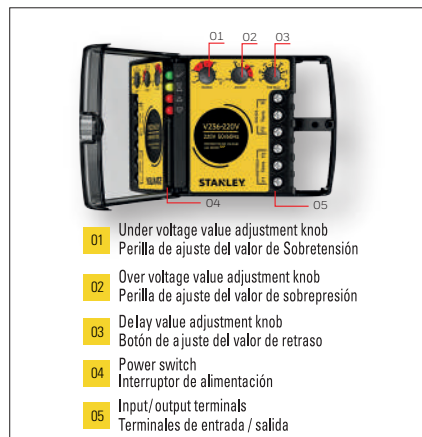

- 01 Under voltage value adjustment knob  
Perilla de ajuste del valor de Sobretenisión
- 02 Over voltage value adjustment knob  
Perilla de ajuste del valor de sobrepresión
- 03 Delay value adjustment knob  
Botón de ajuste del valor de retraso
- 04 Power switch  
Interruptor de alimentación
- 05 Input/output terminals  
Terminales de entrada / salida

#### AVAILABLE OPTIONS:

SXIM-SP-01

#### PERFORMANCE PARAMETER

Finish: Black  
Packing: Blister

#### ENERGY INFORMATION

Voltage: 220V  
Frequency: 50/60Hz  
Current: 40A  
Max Loading: 8800W  
Under voltage: 170V-210V  
Over voltage: 220V-260V



**THE MEASURE OF A PRO™**

# STANLEY

## VOLTAGE & SURGE PROTECTOR

### SXIM-SP-02

### SXIM-SP-03



#### PROTECTION FUNCTION

- Over / Under Voltage Protection.
- Phosphor copper parts.
- Flame retardant shell.

#### COMMON USES

Refrigerators, TV's, freezers, washing machines, water cooler, computers, coffee makers.  
A/C up to 18,000BTU (15Amp)  
A/C up to 30,000BTU (20Amp)

#### ADDITIONAL FEATURES

- Power ON/OFF switch
- Rotatable plug up to 350°
- Easy installation design
- Space-saving format.



#### AVAILABLE OPTIONS:

SXIM-SP-02

SXIM-SP-03

#### PERFORMANCE PARAMETER

Finish: White

Packing: Blister

#### ENERGY INFORMATION

#### SXIM-SP-02

#### SXIM-SP-03

Voltage:

120V

220V

Frequency:

50/60Hz

50/60Hz

Current:

15A

20A

Max Loading:

1800W

4400W

Under voltage:

90-110V

130-180V

Over voltage:

120-140V

230-270V

Delay Time:

5s / 30s / 180s

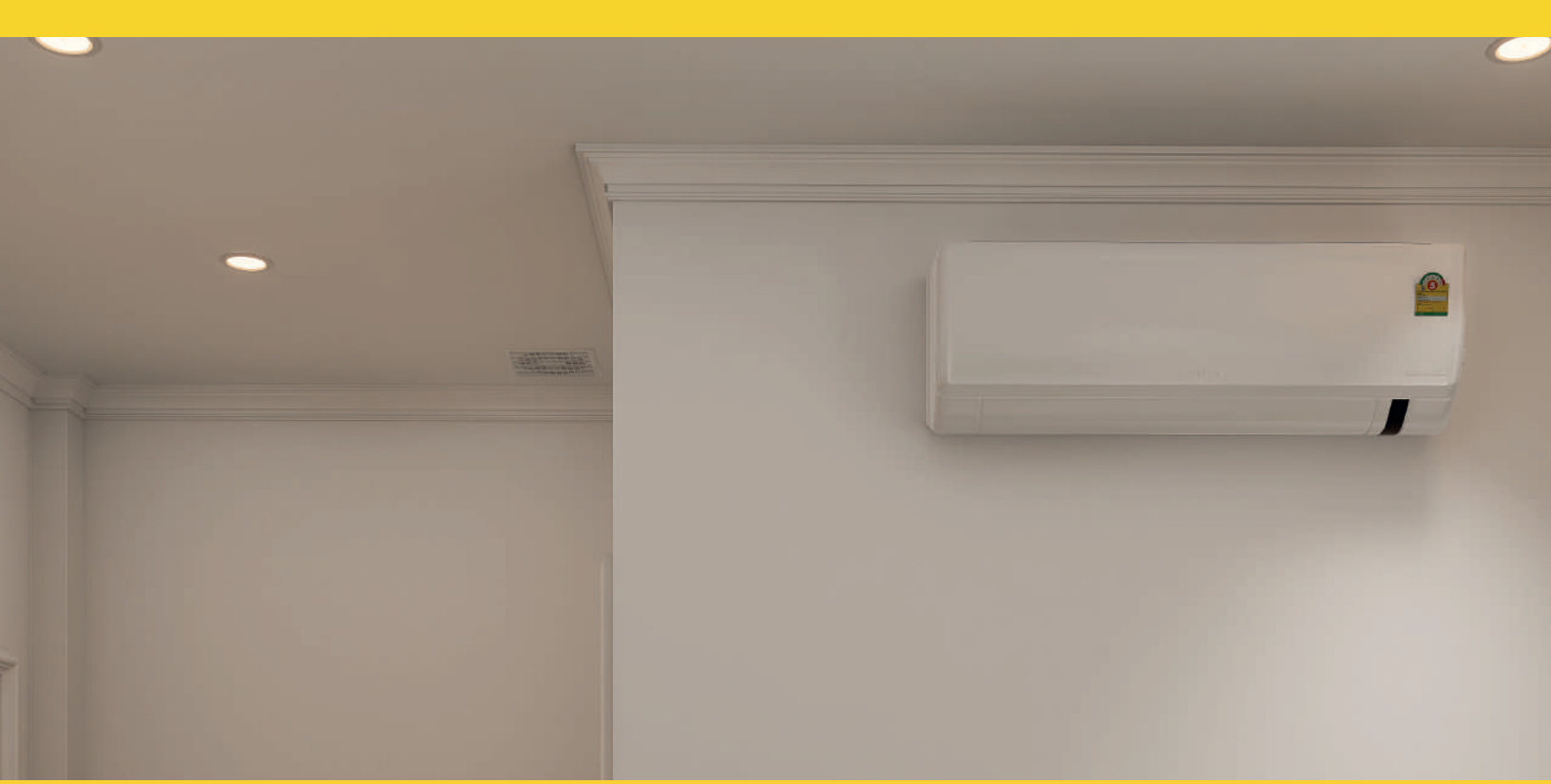

## THE MEASURE OF A PRO™

# STANLEY

## VOLTAGE PROTECTOR

**SXIM-SP-04**

**SXIM-SP-05**



### PROTECTION FUNCTION

- Over / Under Voltage Protection.
- Phosphor copper parts.
- Flame retardant shell.

### COMMON USES

Refrigerators, TVs, freezers, washing machines, water coolers, computers, coffee makers.

- A/C up to 18,000 BTU (120V Model)
- A/C up to 30,000 BTU (220V Model)

### ADDITIONAL FEATURES

- Digital voltage display
- Adjustable protection settings
- Easy installation
- Space-saving compact design

### AVAILABLE OPTIONS:

SXIM-SP-04

SXIM-SP-05

### PERFORMANCE PARAMETER

Finish: White

Packing: Blister

### ENERGY INFORMATION

**SXIM-SP-04**

**SXIM-SP-05**

Voltage:	120V	220V
Frequency:	50/60Hz	50/60Hz
Current:	15A	20A
Under voltage:	65-100V	150-210V
Over voltage:	120-165V	230-280V
Delay Time:	1-999 Seconds (Adjustable)	

**THE MEASURE OF A PRO™**

## VOLTAGE PROTECTOR

### SXIM-SP-06

### SXIM-SP-07



#### PROTECTION FUNCTION

- Over / Under Voltage Protection.
- Phosphor copper parts.
- Flame retardant shell.

#### COMMON USES

Refrigerators, TV's, freezers, washing machines, water coolers, computers, coffee makers.

A/C up to 18,000 BTU (120V model)

A/C up to 30,000 BTU (220V model)

#### ADDITIONAL FEATURES

- Power ON/OFF switch
- Easy installation design
- Space-saving format.

#### AVAILABLE OPTIONS:

SXIM-SP-06

SXIM-SP-07

#### PERFORMANCE PARAMETER

Finish: White

Packing: Blister

#### ENERGY INFORMATION

	SXIM-SP-06	SXIM-SP-07
Voltage:	120V	220V
Frequency:	50/60Hz	50/60Hz
Current:	15A	20A
Under voltage:	90V	165V
Over voltage:	145V	260V
Delay Time:	3 Minutes (By-Pass)	

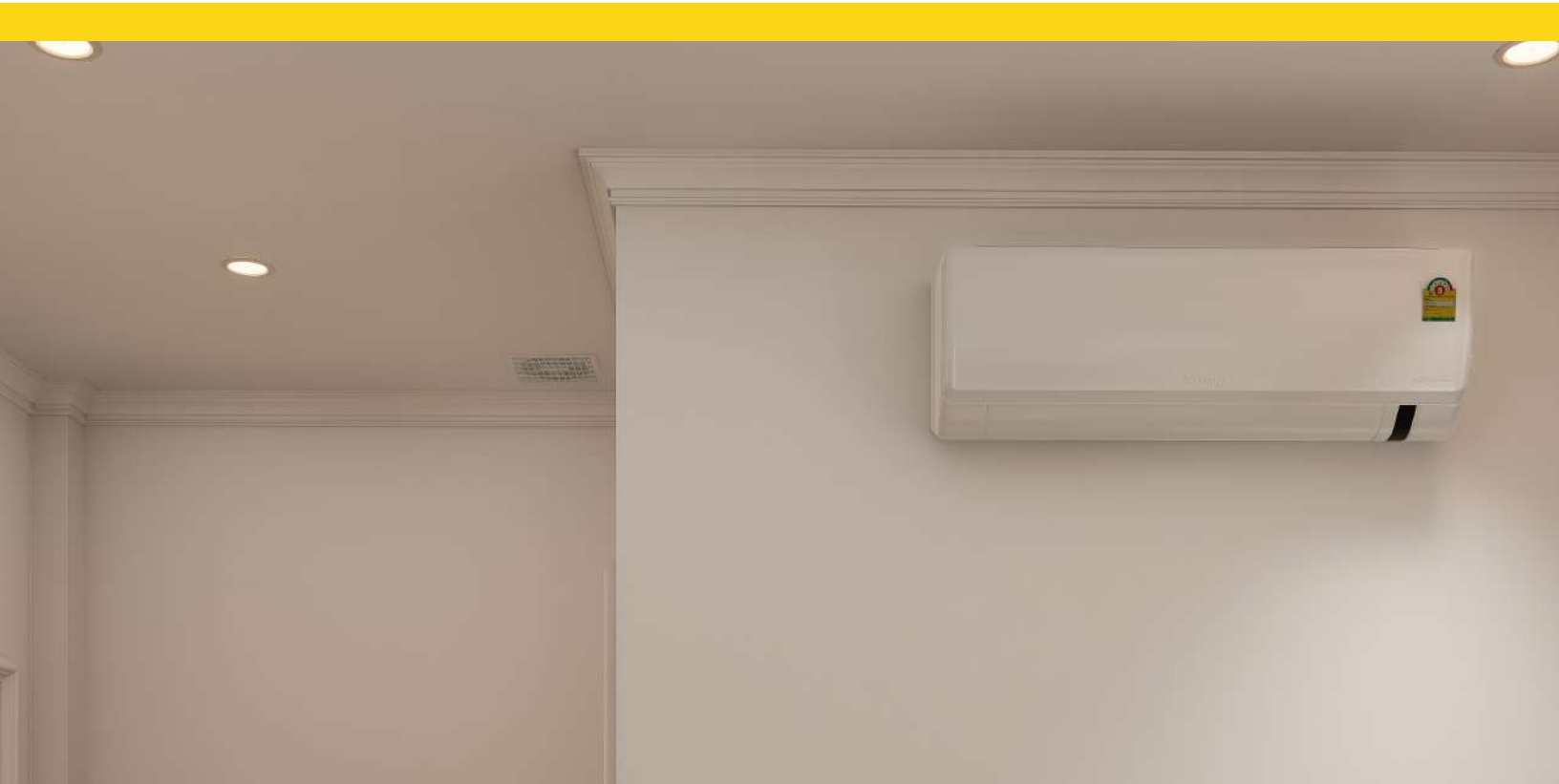

**THE MEASURE OF A PRO™**

# STANLEY

## SURGE PROTECTOR WITH MECHANICAL TIMER

SXIM-SP-08



### PROTECTION FUNCTION

- Over / Under Voltage Protection.
- Lighting Protection.
- Phosphor copper parts.
- Flame retardant shell.

### COMMON USES

Refrigerators, TV's, freezers, washing machines, water cooler, computers, coffee makers, microwaves, electric stoves, and multiple electronic devices.

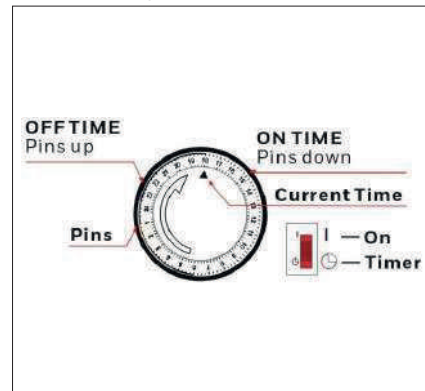

### AVAILABLE OPTIONS:

SXIM-SP-08

### PERFORMANCE PARAMETER

Finish: White  
Packing: Blister

### ENERGY INFORMATION

Voltage: 120V  
Frequency: 50/60Hz  
Current: 15A  
Max Loading: 1800W  
Surge Protect: 350J  
Time Setting: 24 Hours



**THE MEASURE OF A PRO™**

# STANLEY

## VOLTAGE & SURGE PROTECTOR

### SXIM-SP-10



#### PROTECTION FUNCTION

- Over / Under Voltage Protection.
- Phosphor copper parts.
- Flame retardant shell.
- Delay time is 30s.

#### COMMON USES

A/C up to 18,000BTU, refrigerators, TV's, freezers, washing machines, water cooler, computers, coffee makers, microwaves, electric stoves, and multiple electronic devices.

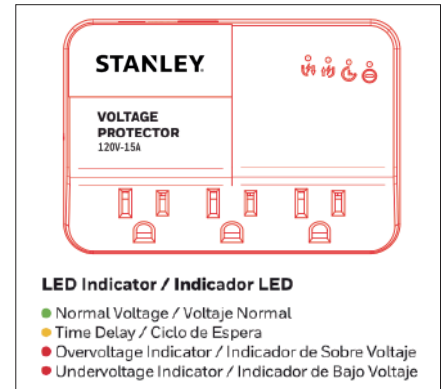

#### AVAILABLE OPTIONS:

SXIM-SP-10

#### PERFORMANCE PARAMETER

Finish: Black  
Packing: Blister  
Delay Time: 30s

#### ENERGY INFORMATION

Voltage: 120V  
Frequency: 50/60Hz  
Current: 15A  
Surge Protection: 140J  
Max Loading: 1800W  
Under voltage: 90V  
Over voltage: 140V



**THE MEASURE OF A PRO™**

# STANLEY



## SOLAR LIGHTING

©2026 Stanley Black & Decker, Inc. Stanley® and the Stanley/ logo are trademarks of Stanley Black & Decker, Inc. or an affiliate thereof and are used under license. Manufactured by Lighting & Hardware Distribution Inc., Panama Headquarters, 1 (888) 502-8432, [www.lightingandhardware.com](http://www.lightingandhardware.com)

# STANLEY

## LED FLOODLIGHT SOLAR

### SXIMSFL01



Outdoor

LED luminaire for street and outdoor lighting, modern and compact design, uniform light projection, high efficiency, long life and easy installation, reduces energy consumption and maintenance costs.

#### FEATURES

- Heavy Duty Die Cast aluminum housing with ample heat sinking.
- LED fixture with bracket can adjustable in 0-270 degrees.
- Control Remote Included
- Slipfit Arm included
- IP65/IK08.
- Long Lifespan.

#### APPLICATION

- Park
- Square
- Trails
- Residential buildings
- Parking lot
- Bridges



#### SPECIFICATIONS

Model	Power	Lumen	Solar Panel	Charging Time
SXIMSFL01-25W3K	25 W	170 Lm/W	8W / 6V	5 Hrs
SXIMSFL01-25W6K	25 W	170 Lm/W	8W / 6V	5 Hrs
SXIMSF-01-60W6K	60 W	170 Lm/W	18W / 6V	6Hrs
SXIMSFL01100W6K	100 W	170 Lm/W	28W / 9V	5Hrs
SXIMSFL01200W3K	200 W	170 Lm/W	35W / 9V	4 Hrs
SXIMSFL01300W6K	300 W	170 Lm/W	35W / 9V	5 Hrs

#### OPTICAL DATA

Color Temperature (CCT)	3000K or 6000K
Beam Angle	110°
Type of Distribution	Direct Symmetrical
Life Span	50 000 H

#### PHYSICAL DATA

Finish	Grey
Protection Level - IP	IP65
Body Frame	Aluminium + ABS
Optical Material	Diffuser PC
Operation Temperature	0°C to +50°C

#### ELECTRICAL DATA

Control Remote Included	YES
Rechargeable battery	LiFePO4
RA	70
Dimmable	NO

#### DIMENSIONS

Model	Size (LxWxH)
SXIMSFL01-25W3K	163x50x185mm
SXIMSFL01-25W6K	163x50x185mm
SXIMSFL01-60W6K	204x55x237mm
SXIMSFL01100W6K	250x55x290mm
SXIMSFL01200W6K	250x55x290mm
SXIMSFL01300W6K	250x55x290mm

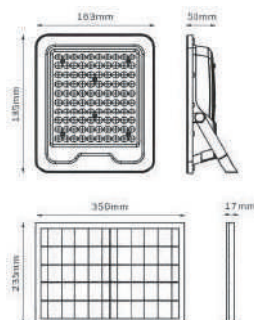

#### LUMINOUS INTENSITY DISTRIBUTION

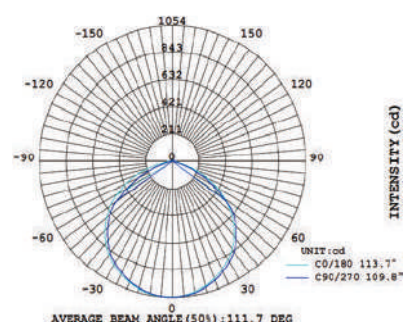

**THE MEASURE OF A PRO™**

# STANLEY

## SOLAR LED OUTDOOR LIGHT

### SXIMSST01

Pole Included



Solar LED lighting, unified structure that includes LED luminaire, solar panel, lithium battery. This new solar technology offers a sustainable, with a minimum of investment and maintenance by not requiring electrical point or be connected to the network.

#### FEATURES

- Heavy Duty ABS + PC, Anti-UV, 94V0 Fire-Proof
- Includes remote control allowing to set working modes, time and sensor settings
- Save Energy
- Longlife Span

#### APPLICATION

- Residential
- Park
- Square
- Parking Lot
- Public or Private roads
- And other places lighting.



Solar Panel



PIR Sensors



Water Proof



Save Money



Life Span  
50,000 H

#### SPECIFICATIONS

Model	Power	Lumen	Solar Panel	Charging Time	Battery Power
SXIMSST01-50W6K	50 W	165 Lm/W	7W / 6V	12 Hrs	12 000 mAh
SXIMSST01-70W6K	70 W	165 Lm/W	9W / 6V	12 Hrs	18 000 mAh
SXIMSST01-100W6K	100 W	165 Lm/W	12W / 9V	12 Hrs	24 000 mAh
SXIMSST01-150W6K	150 W	165 Lm/W	22W / 9V	10 Hrs	36 000 mAh

#### OPTICAL DATA

Color Temperature (CCT)	6000 K
Beam Angle	55°
Type of Distribution	Direct Symmetrical
Life Span	50 000 H

#### PHYSICAL DATA

Finish	Black
Protection Level - IP	IP65
Body Frame	ABS + PC
Optical Material	Diffuser PC
Operation Temperature	-20°C to +50°C

#### ELECTRICAL DATA

Control Remote Included	YES
Rechargeable battery	LiFePO4
RA	70
Dimmable	NO

#### DIMENSIONS

Model	Size (LxWxH)
SXIMSST01-50W6K	385x258x65mm
SXIMSST01-70W6K	460x258x65mm
SXIMSST01-100W6K	616x270x65mm
SXIMSST01-150W6K	778x270x65mm

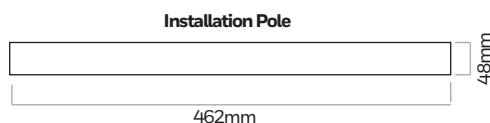

#### LUMINOUS INTENSITY DISTRIBUTION

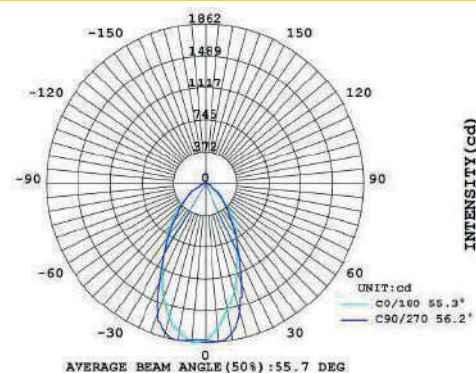

THE MEASURE OF A PRO™

## SOLAR LED OUTDOOR LIGHT

### SXIMSST01

#### SPECIFICATIONS

Model	Rating	Photovoltaic Panel
SXIMSST01-50W6K	DC3.2V 12AH(32700) 13W	6V 7W Monocrystalline
SXIMSST01-70W6K	DC3.2V 18AH(32700) 16W	6V 9W Monocrystalline
SXIMSST01-100W6	DC6.4V 12AH(32700) 27W	9V 12W Monocrystalline
SXIMSST01-150W6	DC6.4V 15AH(32700) 40 W	9V 22W Monocrystalline

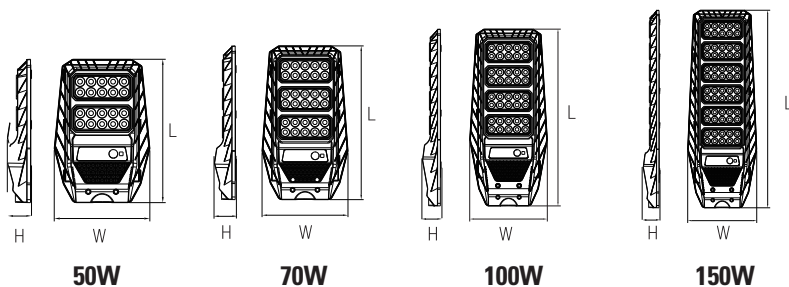

#### WORKING MODES

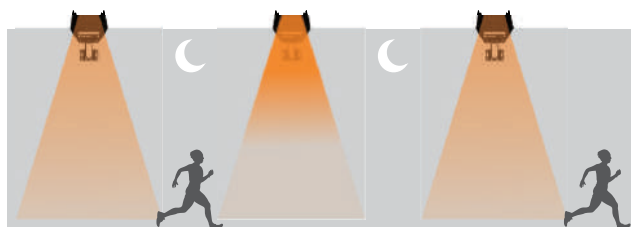

Mode 1: Radar Mode A

The lamp remains off during the daytime. At night, it stays at low brightness when no motion is detected. When motion is detected, the lamp switches to full brightness. Once the person leaves the radar sensor detection range, the lamp remains at full brightness for 15 seconds, then automatically returns to low brightness until dawn, when it turns off.

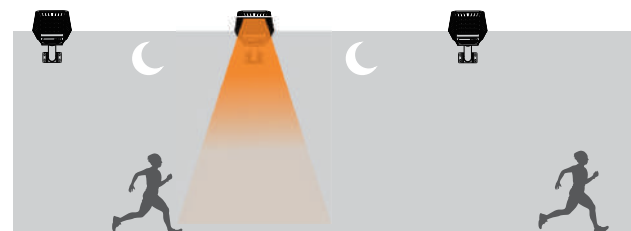

Mode 2: Radar Mode A

The lamp remains off during the daytime and stays off at night when no motion is detected. When motion is detected at night, the lamp switches to full brightness. Once the person leaves the radar sensor detection range, the lamp remains at full brightness for 15 seconds, then automatically turns off until dawn.

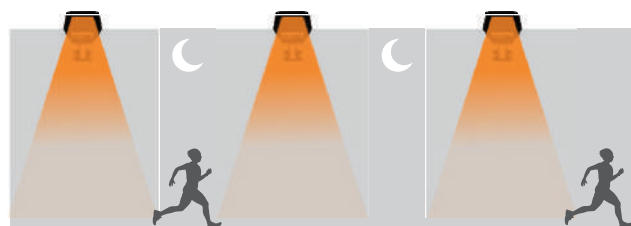

Mode 3: Always - On Mode

The lamp remains off during the daytime and stays at full brightness throughout the night. The radar sensor is disabled in this mode at night.

#### REMOTE CONTROL

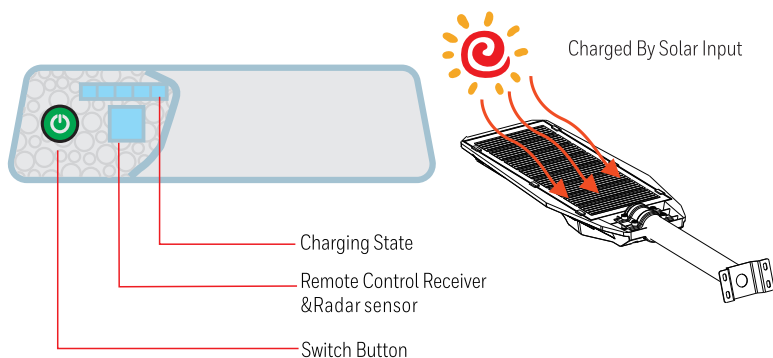

#### NOTE :

Charge the solar lights outdoor for 6-8 hours under the sunshine before first use.

RED : Battery Charging

GREEN : Battery Full

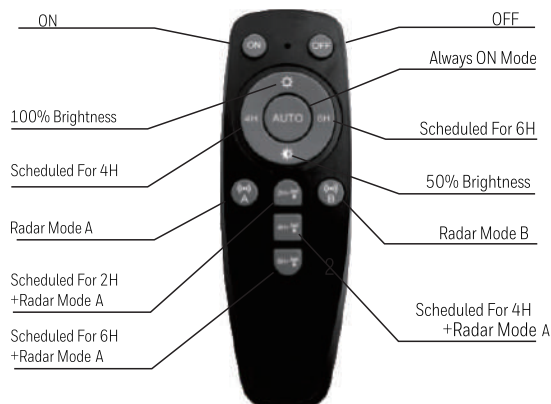

# STANLEY

---

